

## Handles Collection

Philippe Starck  
Enrico Baleri  
Luigi Baroli  
Fabrizio Cester  
Aldo Cibic  
Marcello Cutino  
Riccardo Dalisi  
Elias Segui  
Alvaro Siza Vieira  
Oscar Tusquets Blanca  
Hannes Wettstein  
Dirk Ploos Van Amstel

# KLEIS

made in Italy



## GIARA

Giara è il frutto della passione che Ruggero Frascio, Emanuela Pasini e i figli Giacinto e Raffaele dedicano alla loro attività: ideare e produrre maniglie e complementi per arredamento.

Le quattro collezioni GIARA ART DESIGN, KLEIS, RDS e BRONZE rappresentano quattro mondi, quattro modi di intendere l'architettura dove la maniglia diventa il complemento per donare alle opere quel dettaglio che ne rivela tutta la loro grandezza.

Giara is the fruit of the passion that Ruggero Frascio, Emanuela Pasini and their children Giacinto and Raffaele dedicate to their business: to design and produce handles and furnishing accessories.

The four collections GIARA ART DESIGN, KLEIS, RDS and BRONZE represent four worlds, four ways of understanding the architecture where the handle becomes the complement to give to the works that detail that reveals all their greatness.

Giara ist die Frucht der Leidenschaft, die Ruggero Frascio, Emanuela Pasini und ihre Söhne Giacinto und Raffaele ihrer Arbeit widmen: Griffe und Einrichtungsaccessoires zu entwickeln und herzustellen.

Die vier Kollektionen GIARA ART DESIGN, KLEIS, RDS und BRONZE stellen vier Welten dar; vier Welten die die Architektur auf unterschiedliche Art und Weise verstehen und in denen der Griff zu jenem Detail wird, das die Größe der Kunstwerke in vollem Umfang preisgibt.

Giara est le fruit de la passion que Ruggero Frascio, Emanuela Pasini et leurs enfants Giacinto et Raffaele ont consacré à leur activité : concevoir et fabriquer des poignées et des accessoires de décoration.

Les quatre collections GIARA ART DESIGN, KLEIS, RDS et BRONZE représentent quatre mondes, quatre manières de comprendre l'architecture dans lesquelles la poignée devient l'accessoire pour offrir aux œuvres ce détail qui en révèle toute leur grandeur.



KLEIS

RDS

BRONZE

## Handles Collection



**Sving.** 6-9  
design Dirk Ploos van Amstel



**Antalya.** 12-15  
design Elias Seguí



**Libya.** 16-19  
design Elias Seguí



**Apriti.** 22-25  
design Philippe Starck



**Sesamo.** 26-29  
design Philippe Starck



**Calliope.** 32-35  
design Alvaro Siza Vieira



**Cut.** 38-41  
design Hannes Wettstein



**Sinn.** 42-45  
design Hannes Wettstein



**Fedra.** 48-51  
design Enrico Baleri



**Fedra 2005.** 52-55  
design Enrico Baleri



**Gemma.** 58-61  
design Riccardo Dalisi



**Grafito.** 64-67  
design Marcello Cutino BCF



**La.** 70-73  
design Fabrizio Cester



**Manos.** 76-79  
design Oscar Tusquets Blanca



**Minerva.** 82-85  
design Aldo Cibic



**Tratto.** 88-91  
design Luigi Baroli



**Tratto quad.** 92-95  
design Luigi Baroli

**Accessori** 97  
Accessories / Zubehör / Accessoires

**Finiture** 117  
Finishes / Veredelungen / Finitions

Come ordinare e comporre il codice di acquisto  
How to order and settle the purchase code  
Bestellen und den Kaufcode erstellen  
Comment commander et composer le code d'achat  
vedi pag. 96  
see page / Siehe Seite / voir pag.

# KLEIS



Dirk Ploos Van Amstel	<u>4</u>
Elias Seguí	<u>10</u>
Philippe Starck	<u>20</u>
Alvaro Siza Vieira	<u>30</u>
Hannes Wettstein	<u>36</u>
Enrico Baleri	<u>46</u>
Riccardo Dalisi	<u>56</u>
Marcello Cutino	<u>62</u>
Fabrizio Cester	<u>68</u>
Oscar Tusquets Blanca	<u>74</u>
Aldo Cibic	<u>80</u>
Luigi Baroli	<u>86</u>

## **KLEIS**

### DESIGN D'AUTORE

La collezione di maniglie KLEIS conferma la sua missione d'origine: laboratorio d'eccellenza del pensare e del fare, luogo ideale dove il design e la progettualità comunicano il valore stesso del prodotto. Progetto cui hanno aderito nomi come Philippe Starck, Alvaro Siza, Riccardo Dalisi, Enrico Baleri, Roberto Sambonet, Hannes Wettstein, Oscar Tusquets Blanca, Elias Seguí.... Giara prosegue oggi la ricerca e l'innovazione per produrre pezzi che continuino ad essere testimoni dell'evoluzione concettuale del progetto.

### AUTEUR DESIGN

The Kleis collection of handles reaffirms its original mission: a centre of excellence for ideas and actions, an ideal laboratory where design and project development convey the same values as the product. A project backed by such names as Philippe Starck, Alvaro Siza, Riccardo Dalisi, Enrico Baleri, Roberto Sambonet, Hannes Wettstein, Oscar Tusquets Blanca, Elias Seguí.... Giara is continuing its research and innovation to produce items that will continue to further the conceptual evolution of design.

### NAMHAFTES DESIGN

Die Kleis Drückerkollektion unterstreicht ihre ursprüngliche Mission: ein Kompetenzzentrum für Ideen und deren Umsetzung, ein idealer Ort, an dem Design, Entwicklung und Produkt die gleichen Werte teilen. Ein Projekt unterstützt von Design-Ikonen wie Philippe Starck, Alvaro Siza, Riccardo Dalisi, Enrico Baleri, Roberto Sambonet, Hannes Wettstein, Oscar Tusquets Blanca, Elias Seguí ... Giara steht für Forschung und innovative Produkte zur Förderung konzeptioneller Entwicklung von Design.

### DESIGN D'AUTORE

La collection de poignées KLEIS réaffirme sa mission d'origine: un centre d'excellence pour les idées et actions, un laboratoire idéal où le design et le développement de projets véhiculent les mêmes valeurs que le produit. Un projet soutenu par des noms tels que Philippe Starck, Alvaro Siza, Riccardo Dalisi, Enrico Baleri, Roberto Sambonet, Hannes Wettstein, Oscar Tusquets Blanca, Elias Seguí ... Giara poursuit la recherche et l'innovation pour produire des articles qui continueront à favoriser l'évolution conceptuelle du Design.

# KLEIS



Thanks, No Sugar 2013



**DIRK PLOOS VAN AMSTEL**  
DESIGNER

Laureato con un Master of Arts in User Interaction Design presso l'Università di Utrecht, nel 2011 ha fondato il proprio studio a Maastricht. Dirk fa parte di un gruppo accademico di ricerca sui cambiamenti comportamentali dettati dalla persuasività del design. Il suo studio ha ottenuto riconoscimenti alla Biennale Interieur Award del 2014. Suoi lavori sono presenti nel prestigioso catalogo Star Product Designers della HarperCollins di New York.

Dirk Ploos van Amstel creates transparent, open designs in a style that conveys the impact and immediacy of Pop cartoons. His creations reflect the conviction that users form stronger bonds with products when their function is plain to see. In other words, when function is an integral part of form. In the case of SVING, the key and lock mechanism is taken out from its hiding place inside the door panel and linked directly to the handle.

The result: a clear, straightforward assembly with a balanced image.

Nach seinem Masterabschluss in „Arts in User Interaction Design“ an der Universität Utrecht, hat er 2011 sein eigenes Studio in Maastricht eröffnet. Er ist Teil einer Forschungsgruppe, die sich mit dem Einfluss von Design auf sich veränderndes Verhalten beschäftigt. Sein Studio erhielt 2014 den Biennale Interieur Award. Seine Arbeiten sind ebenfalls im bekannten „Star Product Designers Katalog“ von HarperCollins in New York zu finden.

Dirk a reçu son Master en Art sur l'interaction entre utilisateur et Design à l'Université d'Utrecht, et en 2011, il a donc créé son propre cabinet à Maastricht. Il fait partie d'un groupe de recherche universitaire qui étudie les changements de comportement induits par la

force de persuasion du design. Son cabinet a reçu le Prix réservé au design d'Intérieur de la Biennale en 2014. Ses œuvres sont apparues dans le prestigieux catalogue de Harper Collins (New York) dédié aux vedettes du Design.

KLEIS



**Sving.**

2015



## Sving.

design Dirk Ploos van Amstel

materiale / material  
Acciaio / Stainless steel

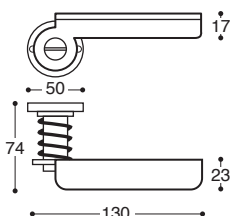

finiture standard / standard finishes



**AB** - Acciaio satinato + bianco  
Satin steel + white



**AN** - Acciaio satinato + nero  
Satin steel + black



**AR** - Acciaio satinato + rosso  
Satin steel + red

finiture trendy / trendy finishes



**GB** - Gun metal + bianco  
Gun metal + white



**GN** - Gun metal + nero  
Gun metal + black



**GR** - Gun metal + rosso  
Gun metal + red



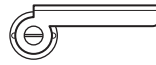

**KSVI10**  
S/bocchetta / Latch

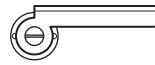

**KSVI12**  
Patent / Lock

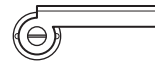

**KSVI14**  
Yale / Cylinder

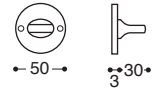
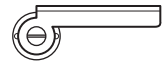

**KSVI16**  
WC / Privacy - Q. 6/7/8

**Sving/SV** Rosetta metallo - con molla / **Metal rose** - springloaded

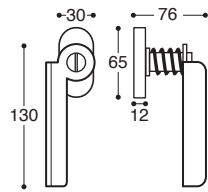

**KSVI1J**  
SX / LH

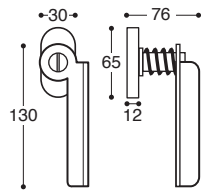

**KSVI1I**  
DX / RH

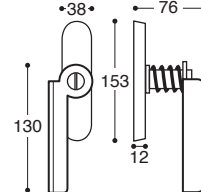

**KSVI1L**  
SX / LH

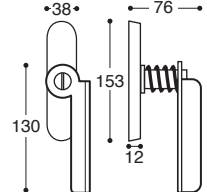

**KSVI1K**  
DX / RH

**Sving DK** - mov. 8 scatti  
Window handle - 8 pos. mech.

**Sving Martellina**  
Per finestra - Cremonese / For window - Cremon

Material / material  
Edelsthal / Stainless steel



**Sving.**  
design Dirk Ploos van Amstel

Standardveredelungen / standard finishes



**AB** - Edelsthal + weiß  
Satin steel + white



**AN** - Edelsthal + Schwarz  
Satin steel + black



**AR** - Edelsthal + Rot  
Satin steel + red

Trendy Veredelungen / trendy finishes



**GB** - Gun metal + weiß  
Gun metal + white



**GN** - Gun metal + Schwarz  
Gun metal + black



**GR** - Gun metal + Rot  
Gun metal + red

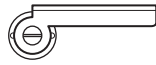

**KSVI11**

Ohne Schlüssel / Latch

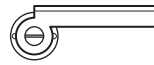

**KSVI13**

BB / Lock

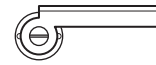

**KSVI15**

PZ / Cylinder

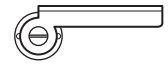

**KSVI17**

BAD S. 6/7/8 / Privacy

**Sving/SV** Türgriff - Metall Rosetten DIN 38 mm - Mit Feder / **Metal rose** - springloaded

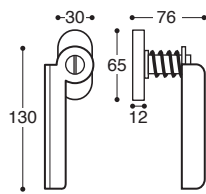

**KSVI1J**

Links / LH

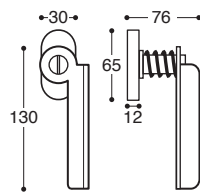

**KSVI1I**

Rechts / RH

**Sving DK** Fenstergriffe - Mit Rastung  
Window handle - 8 pos. mech.

matériau / material  
Acier / Stainless steel

standard 

**Sving.**  
design Dirk Ploos van Amstel

finitions standards / standard finishes



**AB** - Acier + blanc  
Satin steel + white



**AN** - Acier + noir  
Satin steel + black



**AR** - Acier + rot  
Satin steel + red

finitions trendy / trendy finishes



**GB** - Gun metal + blanc  
Gun metal + white



**GN** - Gun metal + noir  
Gun metal + black



**GR** - Gun metal + rot  
Gun metal + red

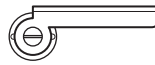

**KSVI1S**  
BDC / Latch

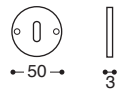
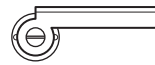

**KSVI1P**  
Cle L / Lock

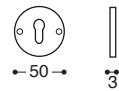
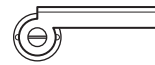

**KSVI1Y**  
PZ / Cylinder

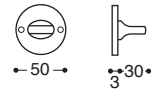
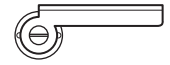

**KSVI1W**  
Cond/Dec C. 6/7/8 / Privacy

**Sving/SV Métal rosace** - avec ressort, carré 7 mm / **Metal rose** - springloaded

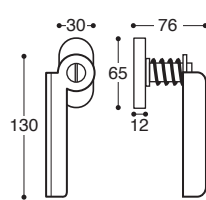

**KSVI1I**  
Droit / RH

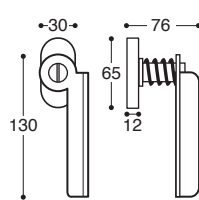

**KSVI1J**  
Gauche / LH

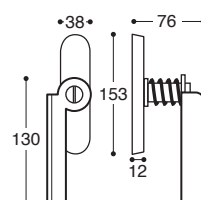

**KSVI1K**  
Droit / RH

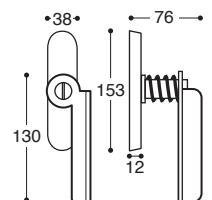

**KSVI1L**  
Gauche / LH

**Sving DK** Poignée de fenetre  
Mécan. 8 positions / Window handle - 8 pos. mech.

**Sving Martellina** Poignée de fenetre  
Crémone / Window handle - Cremon



Barcelona

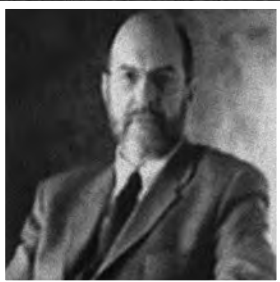

**ELIAS SEGUÌ**  
DESIGNER

Elias Seguí è nato a Barcellona (Spagna) nel 1945. Fa parte della prima generazione di designer professionisti in Spagna. Nel 1970 fonda uno studio di industrial e interior design, avviando così collaborazioni con diversi studi di Architettura e Urbanistica. Insegnante in diverse scuole di Design di Barcellona. Scrive articoli su diverse riviste di Architettura e design. Impegnato politicamente come Assessore all'ambiente. Tema centrale dei suoi progetti, è l'oggetto domestico.

Born in Barcelona in 1945. Major figure in the first generation of professional designers in Spain. In 1970 he founded a studio of industrial and interior design, which opened the doors to collaborations with various architectural and urban planning studios. He continues to teach in a number of design schools in Barcelona, and writes articles for various architecture and design

journals. As for politics, he is Barcelona's Environmental Commissioner. The central theme of his design and thought is the domestic object.

Elias Seguí ist in Barcellona (Spanien) 1945 geboren. Er gehört zu der ersten Generation von professionellen Designer in Spanien. 1970 gründet er ein Atelier für industrial and interior design und arbeitet so mit zahlreichen Architekturbüros und Städteplanungsbüros zusammen. Er übt die Lehrtätigkeit in verschiedenen Designschulen in Barcelona aus. Er schreibt Artikel in zahlreichen Architektur- und Designzeitschriften. Politisch engagierte er sich als Stadtrat für die Umwelt. Zentrales Thema seiner Projekte ist der häusliche Gegenstand.

Elias Seguí est né à Barcelone (Espagne) en 1945. Il fait partie de la première génération de

designers professionnels en Espagne. En 1970, il fonde un studio de design industriel et d'intérieur, démarrant ainsi des collaborations avec plusieurs studios d'Architecture et d'Urbanisme. Il enseigne dans plusieurs écoles de Design de Barcelone. Il écrit des articles dans plusieurs revues d'Architecture et de design. Il est engagé politiquement comme Adjoint en charge de l'environnement. Le thème central de ses projets est l'objet de maison.



**Antalya.**

2000

**Libya.**

2000

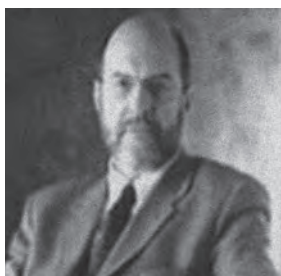

## Antalya.

design Elias Segù

materiale / material  
**Ottone / Brass**

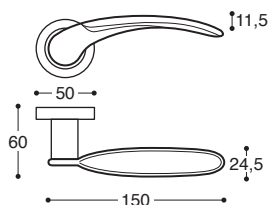

finiture standard / standard finishes



**01** - Bi-oro  
Polished&satin brass



**06** - Cromo lucido  
Polished chrome



**88** - Bi-cromo  
Polished&satin chrome

finiture trendy / trendy finishes









**G3** - Gun metal





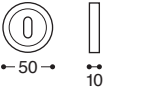

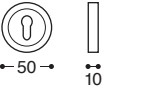

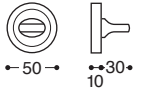
**15** - Nero opaco\*  
Mat black\*





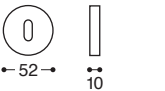

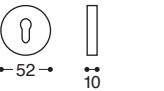

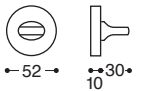
**16** - Bianco\*  
White\*

  <b>K00AA0</b> S/bocchetta / Latch	  <b>K00AA2</b> Patent / Lock	  <b>K00AA4</b> Yale / Cylinder	  <b>K00AA6</b> WC / Privacy - Q. 6/7/8
--	--	--	--

**Antalya/HB6** Rosetta metallo - con molla / Metal rose - springloaded

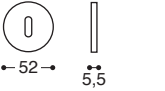
  <b>K00A10</b> S/bocchetta / Latch	  <b>K00A12</b> Patent / Lock	  <b>K00A14</b> Yale / Cylinder	  <b>K00A16</b> WC / Privacy - Q. 6/7/8
--	--	--	--

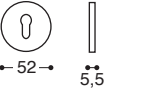
**Antalya/T11** Rosetta metallo - con molla / Metal rose - springloaded

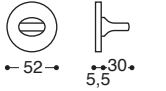
  <b>K00AP0</b> S/bocchetta / Latch	  <b>K00AP2</b> Patent / Lock	  <b>K00AP4</b> Yale / Cylinder	  <b>K00AP6</b> WC / Privacy - Q. 6/7/8
--	--	--	--

**Antalya/FLT** Rosetta ribassata metallo - con molla / Metal flat rose - springloaded

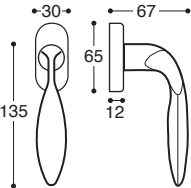
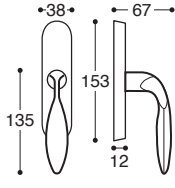
 <b>K00BAI</b> Senza mano / Without hand	 <b>K00BAK</b> Senza mano / Without hand
---	---

**Antalya DK** - mov. 8 scatti  
Window handle - 8 pos. mech.

**Antalya Martellina**  
Per finestra - Cremonese / For window - Cremon

\* a richiesta / on demand

Material / material  
Messing / Brass

standard 

**Antalya.**  
design Elias Segui

Standardveredelungen / standard finishes



**01** - Messing poliert/Matt  
Polished&satin brass



**06** - Chrom  
Polished chrome



**88** - Chrom/Chrom Matt  
Polished&satin chrome

Trendy Veredelungen / trendy finishes



**G3** - Gun metal



**15** - Matt schwarz\*  
Mat black\*



**16** - Weiß\*  
White\*



**K00A10**

Ohne Schlüssel / Latch

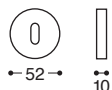

**K00A13**

BB / Lock

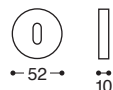

**K00A15**

PZ / Cylinder

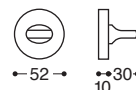

**K00A17**

BAD S. 6/7/8 / Privacy

**Antalya/T11** Türgriff - Metall Rosetten DIN 38 mm - Mit Feder / **Metal rose** - springloaded



**K00AS0**

Ohne Schlüssel / Latch

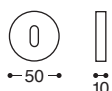

**K00AS3**

BB / Lock

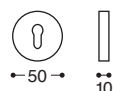

**K00AS5**

PZ / Cylinder

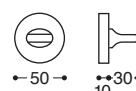

**K00AS7**

BAD S. 6/7/8 / Privacy

**Antalya/52D** Türgriff - Metall Rosetten DIN 38 mm - Mit Feder / **Metal rose** - springloaded

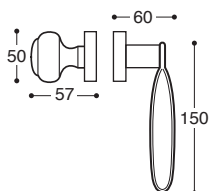

**K00A1D**

PZ, Links / LH

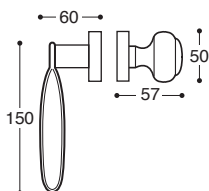

**K00A1C**

PZ, Rechts / RH

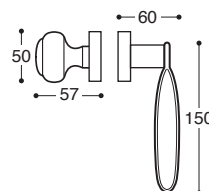

**K00ASD**

PZ, Links / LH

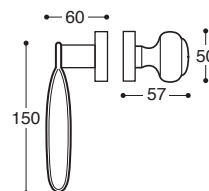

**K00ASC**

PZ, Rechts / RH

**Antalya/T11**  
Metall Rosetten - Wechselgarnitur

**Antalya/52D**  
Metall/Kunststoff Rosetten - Wechselgarnitur

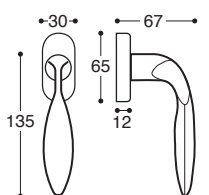

**K00BAI**

Ohne Hand / Without hand

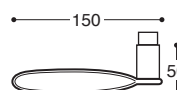

**K00A09**

Links / LH

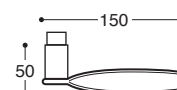

**K00A08**

Rechts / RH

**Antalya DK** Fenstergriffe - Mit Rastung  
Window handle - 8 pos. mech.

**Antalya**  
Drückerlochteil - Ohne Rosetten

\* auf Anfrage / on demand



matériau / material  
Laiton / Brass

standard 

**Antalya.**  
design Elias Seguí

finitions standards / standard finishes



**01** - Laiton poli + satiné  
Polished&satin brass



**06** - Chrome poli  
Polished chrome



**88** - Chrom poli + satiné  
Polished&satin chrome

finitions trendy / trendy finishes



**G3** - Gun metal



**15** - Noir mat\*  
Mat black\*



**16** - Blanc\*  
White\*



**K00AAS**  
BDC / Latch

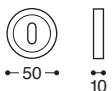

**K00AAP**  
Cle L / Lock

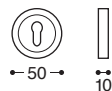

**K00AAY**  
Cle I / Cylinder



**K00AAW**  
Cond/Dec C. 6/7/8 / Privacy

**Antalya/HB6 Métal rosace - avec ressort, carré 7 mm / Metal rose - springloaded**



**K00A1S**  
BDC / Latch

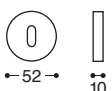

**K00A1P**  
Cle L / Lock

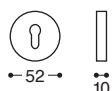

**K00A1Y**  
Cle I / Cylinder

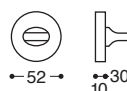

**K00A1W**  
Cond/Dec C. 6/7/8 / Privacy

**Antalya/T11 Métal rosace - avec ressort, carré 7 mm / Metal rose - springloaded**



**K00APS**  
BDC / Latch

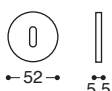

**K00APP**  
Cle L / Lock

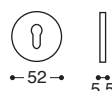

**K00APY**  
Cle I / Cylinder

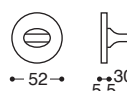

**K00APW**  
Cond/Dec C. 6/7/8 / Privacy

**Antalya/FLT Rosette abaissée métal - avec ressort, carré 7 mm / Metal flat rose - springloaded**

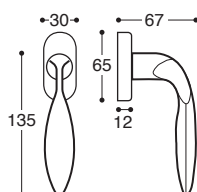

**K00BAI**  
Sans main / Without hand

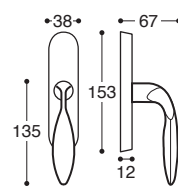

**K00BAK**  
Sans main / Without hand

**Antalya DK** Poignée de fenetre  
Mécan. 8 positions / Window handle - 8 pos. mech.

**Antalya Martellina** Poignée de fenetre  
Crémone / Window handle - Cremon

\* sur demande / on demand

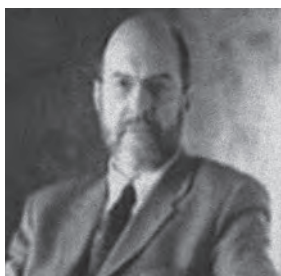

## Libya.

design Elias Segù

materiale / material  
Ottone / Brass

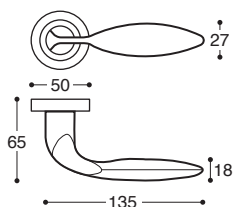

finiture standard / standard finishes



**01** - Bi-oro  
Polished&satin brass



**06** - Cromo lucido  
Polished chrome



**88** - Bi-cromo  
Polished&satin chrome

finiture trendy / trendy finishes





**G3** - Gun metal







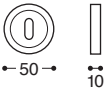
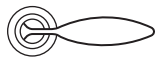
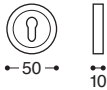
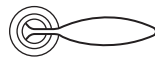
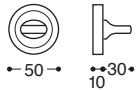

**15** - Nero opaco\*  
Mat black\*





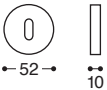

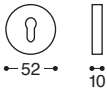

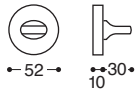
**16** - Bianco\*  
White\*

 <p><b>K00BA0</b> S/bocchetta / Latch</p>	  <p><b>K00BA2</b> Patent / Lock</p>	  <p><b>K00BA4</b> Yale / Cylinder</p>	  <p><b>K00BA6</b> WC / Privacy - Q. 6/7/8</p>
--	---	---	---

**Libya/HB6 Rosetta metallo - con molla / Metal rose - springloaded**

 <p><b>K00B10</b> S/bocchetta / Latch</p>	  <p><b>K00B12</b> Patent / Lock</p>	  <p><b>K00B14</b> Yale / Cylinder</p>	  <p><b>K00B16</b> WC / Privacy - Q. 6/7/8</p>
--	---	---	---

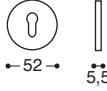
**Libya/T11 Rosetta metallo - con molla / Metal rose - springloaded**

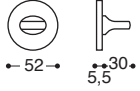
 <p><b>K00BP0</b> S/bocchetta / Latch</p>	  <p><b>K00BP2</b> Patent / Lock</p>	  <p><b>K00BP4</b> Yale / Cylinder</p>	  <p><b>K00BP6</b> WC / Privacy - Q. 6/7/8</p>
--	---	---	---

**Libya/FLT Rosetta ribassata metallo - con molla / Metal flat rose - springloaded**

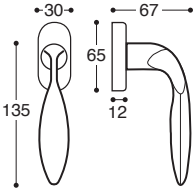
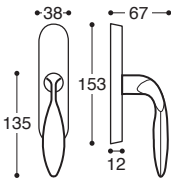
 <p><b>K00BAI</b> Senza mano / Without hand</p>	 <p><b>K00BAK</b> Senza mano / Without hand</p>
--	--

**Libya DK - mov. 8 scatti**  
Window handle - 8 pos. mech.

**Libya Martellina**  
Per finestra - Cremonese / For window - Cremon

\* a richiesta / on demand

Material / material  
Messing / Brass

standard 

**Libya.**  
design Elias Segui

Standardveredelungen / standard finishes



**01** - Messing poliert/Matt  
Polished&satin brass



**06** - Chrom  
Polished chrome



**88** - Chrom/Chrom Matt  
Polished&satin chrome

Trendy Veredelungen / trendy finishes



**G3** - Gun metal



**15** - Matt schwarz\*  
Mat black\*



**16** - Weiß\*  
White\*



**K00B10**

Ohne Schlüssel / Latch

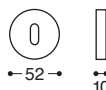

**K00B13**

BB / Lock

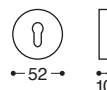

**K00B15**

PZ / Cylinder

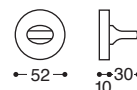

**K00B17**

BAD S. 6/7/8 / Privacy

**Libya/T11** Türgriff - Metall Rosetten DIN 38 mm - Mit Feder / **Metal rose** - springloaded



**K00BS0**

Ohne Schlüssel / Latch

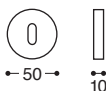

**K00BS3**

BB / Lock



**K00BS5**

PZ / Cylinder



**K00BS7**

BAD S. 6/7/8 / Privacy

**Libya/52D** Türgriff - Metall/Kunststoff Rosetten DIN 38 mm - Mit Feder  
**Metal&plastic rose** - springloaded

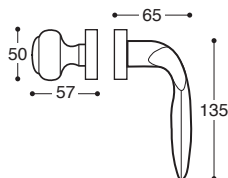

**K00B1D**

PZ, Links / LH

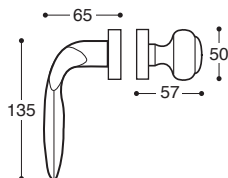

**K00B1C**

PZ, Rechts / RH

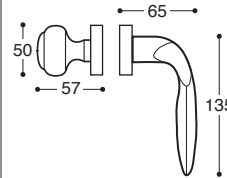

**K00BSD**

PZ, Links / LH

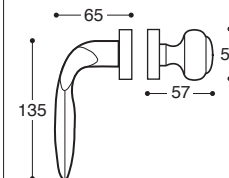

**K00BSC**

PZ, Rechts / RH

**Libya/T11**  
**Metall Rosetten** - Wechselgarnitur

**Libya/52D**  
**Metall/Kunststoff Rosetten** - Wechselgarnitur

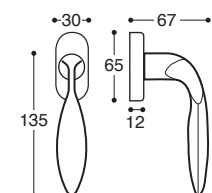

**K00BAI**

Ohne Hand / Without hand

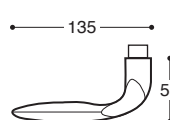

**K00B09**

Links / LH

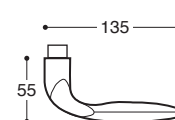

**K00B08**

Rechts / RH

**Libya DK** Fenstergriffe - Mit Rastung  
Window handle - 8 pos. mech.

**Libya**  
Drückerlochteil - Ohne Rosetten

\* auf Anfrage / on demand

matériau / material  
Laiton / Brass

standard 

**Libya.**  
design Elias Seguí

finitions standards / standard finishes



**01** - Laiton poli + satiné  
Polished&satin brass



**06** - Chrome poli  
Polished chrome



**88** - Chrom poli + satiné  
Polished&satin chrome

finitions trendy / trendy finishes



**G3** - Gun metal



**15** - Noir mat\*  
Mat black\*



**16** - Blanc\*  
White\*



**K00BAS**  
BDC / Latch

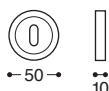

**K00BAP**  
Cle L / Lock

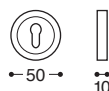

**K00BAY**  
Cle I / Cylinder

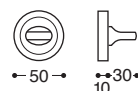

**K00BAW**  
Cond/Dec C. 6/7/8 / Privacy

**Libya/HB6 Métal rosace - avec ressort, carré 7 mm / Metal rose - springloaded**



**K00B1S**  
BDC / Latch

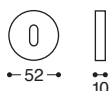

**K00B1P**  
Cle L / Lock

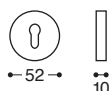

**K00B1Y**  
Cle I / Cylinder

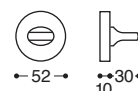

**K00B1W**  
Cond/Dec C. 6/7/8 / Privacy

**Libya/T11 Métal rosace - avec ressort, carré 7 mm / Metal rose - springloaded**



**K00BPS**  
BDC / Latch

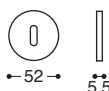

**K00BPP**  
Cle L / Lock

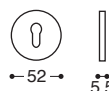

**K00BPY**  
Cle I / Cylinder

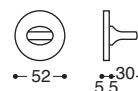

**K00BPW**  
Cond/Dec C. 6/7/8 / Privacy

**Libya/FLT Rosette abaissée métal - avec ressort, carré 7 mm / Metal flat rose - springloaded**

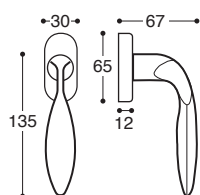

**K00BAI**  
Sans main / Without hand

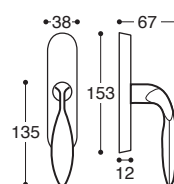

**K00BAK**  
Sans main / Without hand

**Libya DK** Poignée de fenêtre  
Mécan. 8 positions / Window handle - 8 pos. mech.

**Libya Martellina** Poignée de fenêtre  
Crémone / Window handle - Cremon

\* sur demande / on demand



Asahi Super Dry Hall 1989

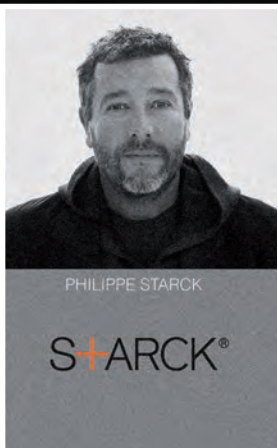

## PHILIPPE STARCK DESIGNER

Nato a Parigi, 1949, designer e architetto. Tra i designer che più ha segnato la cultura del design nell'ultimi trent'anni per originalità e fecondità, oltre al design di prodotto svolge attività di progettazione architettonica. Nel 1968 fonda la Quasar per la produzione di oggetti gonfiabili. Dal 1971 a 1972 è direttore artistico della Pierre Cardin; nel 1979 apre lo studio di design. L'occasione di balzare alle cronache giunge dalla committenza di François Mitterrand per arredi dell'Eliseo, 1984. Autore di numerosi locali e opere architettoniche nelle più importanti metropoli mondiali è vincitore di innumerevoli importanti premi internazionali spazia a 360° nel mondo della progettazione, collaborando con le più prestigiose firme del mondo dell'arredo, del complemento e dei veicoli.

Born in Paris, 1949, designer and architect. Among designers who have most marked the design culture for the last thirty years for their originality and fertility, in addition to the product design, he carries out architectural design activities. In 1968 he founded Quasar for the production of inflatable items. From 1971 to 1972 he was artistic director of Pierre Cardin; In 1979 he opened the design studio. The occasion to jump to the chronicles comes from the commission of François Mitterrand for furnishings of the Eliseo, 1984. He is the author of many local and architectural works in the world's most important metropolises, and he is the winner of countless important international awards ranging from 360° to the world of design, collaborating with the most prestigious brands in the world of furniture, complement and vehicles.

1949 in Paris geboren, Designer und Architekt. Er ist einer der Designer, der die Kultur des Designs in den letzten dreißig Jahren aufgrund seiner Originalität und Fruchtbarkeit sehr stark mitgeprägt hat; neben dem Produktdesign arbeitet er auch als Architekt. 1968 gründet er Quasar, ein Unternehmen, das aufblasbare Objekte herstellt. Von 1971 bis 1972 war er künstlerischer Leiter bei Pierre Cardin; 1979 eröffnet er sein eigenes Design-Studio. Dank eines Auftrags von François Mitterrand, den Élysée-Palast einzurichten, gelangte er 1984 zu Ruhm. Er ist Autor zahlreicher Lokale und architektonischer Werke in den wichtigsten Metropolen der Welt und Gewinner von unzähligen großen internationalen Preisen. Er passt sich an jegliche Art der Planung an und arbeitet mit den renommiertesten Namen in der Welt der Einrichtungen, Accessoires und Fahrzeuge zusammen.

Né à Paris en 1949 c'est un designer et un architecte. Parmi les designers qui ont le plus marqués la culture du design ces trente dernières années en raison de son originalité et de sa productivité, en plus de la conception des produits, il réalise des activités de conception architecturale. En 1968 il fonde Quasar pour la fabrication d'objets gonflables. De 1971 à 1972 il est directeur artistique de Pierre Cardin ; en 1979 il ouvre un cabinet de design. La décoration de l'Élysée à l'époque de François Mitterrand en 1984 lui donne l'occasion de faire la une de l'actualité. Auteur de nombreuses pièces et œuvres architecturales dans les plus importantes métropoles mondiales, il a remporté de nombreux prix internationaux importants. Il collabore avec les marques les plus prestigieuses du monde de la décoration, des accessoires et de l'automobile.



**Apriti.**

1991

**Sesamo.**

1991



## Apriti. design Philippe Starck

materiale / material  
**Alluminio tecnologico**  
**Techno aluminum**

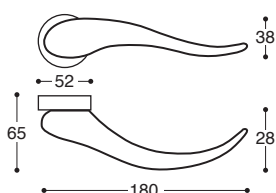

finiture standard / standard finishes



**o6** - Cromo lucido  
Polished chrome



**o8** - Cromo satinato  
Satin chrome



**SL** - Silver

finiture trendy / trendy finishes



**G3** - Gun metal



**15** - Nero opaco\*  
Mat black\*



**16** - Bianco\*  
White\*

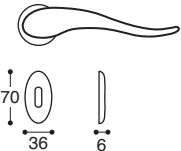
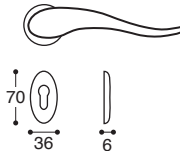
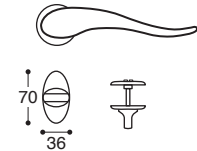

  <p><b>K00090</b> S/bocchetta / Latch</p>	  <p><b>K00092</b> Patent / Lock</p>	  <p><b>K00094</b> Yale / Cylinder</p>	  <p><b>K00096</b> WC / Privacy - Q. 6/7/8</p>
---	---	---	---

**Apriti Rosetta metallo&plastica - senza molla / Metal&plastic rose - without spring**

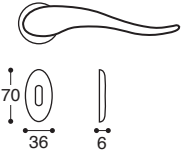
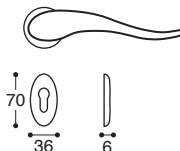
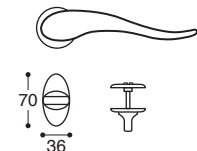
  <p><b>K00010</b> S/bocchetta / Latch</p>	  <p><b>K00012</b> Patent / Lock</p>	  <p><b>K00014</b> Yale / Cylinder</p>	  <p><b>K00016</b> WC / Privacy - Q. 6/7/8</p>
---	---	---	---

**Apriti/T11 Rosetta metallo - con molla / Metal rose - springloaded**

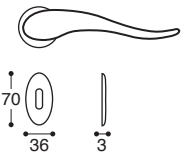
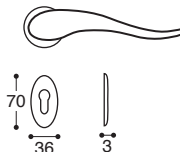
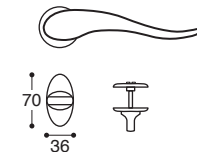
  <p><b>K000P0</b> S/bocchetta / Latch</p>	  <p><b>K000P2</b> Patent / Lock</p>	  <p><b>K000P4</b> Yale / Cylinder</p>	  <p><b>K000P6</b> WC / Privacy - Q. 6/7/8</p>
---	---	---	---

**Apriti/FLT Rosetta ribassata metallo - con molla / Metal flat rose - springloaded**

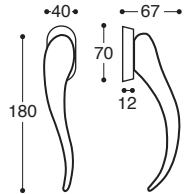
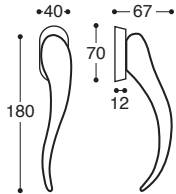
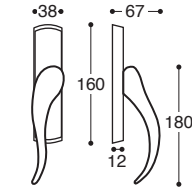
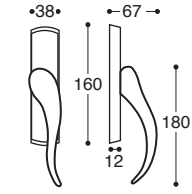
  <p><b>K0009J</b> SX / LH</p>	  <p><b>K0009I</b> DX / RH</p>	  <p><b>K0009L</b> SX / LH</p>	  <p><b>K0009K</b> DX / RH</p>
---	---	---	---

**Apriti DK - mov. 8 scatti**  
Window handle - 8 pos. mech.

**Apriti Martellina**  
Per finestra - Cremonese / For window - Cremon

\* a richiesta / on demand

Material / material  
Tech-Aluminium  
Techno aluminium



**Apriti.**  
design Philippe Starck

Standardveredelungen / standard finishes



**o6** - Chrom  
Polished chrome



**o8** - Chrom matt  
Satin chrome



**SL** - Silber  
Silver

Trendy Veredelungen / trendy finishes



**G3** - Gun metal



**15** - Matt schwarz\*  
Mat black\*



**16** - Weiß\*  
White\*



**K00010**

Ohne Schlüssel / Latch

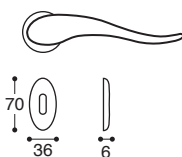

**K00013**

BB / Lock

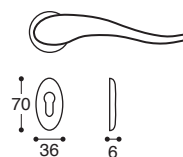

**K00015**

PZ / Cylinder

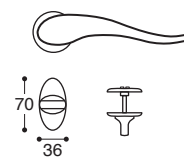

**K00017**

BAD S. 6/7/8 / Privacy

**Apriti/T11 Türgriff** - Metall Rosetten DIN 38 mm - Mit Feder / **Metal rose** - springloaded



**K000S0**

Ohne Schlüssel / Latch

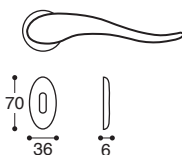

**K000S3**

BB / Lock

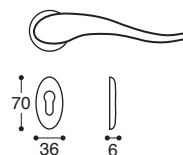

**K000S5**

PZ / Cylinder

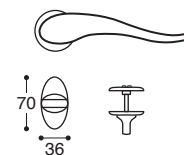

**K000S7**

BAD S. 6/7/8 / Privacy

**Apriti/52D Türgriff** - Metall/Kunststoff Rosetten DIN 38 mm - Mit Feder  
**Metal&plastic rose** - springloaded

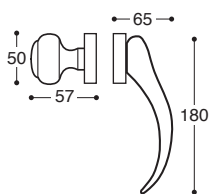

**K0001D**

PZ, Links / LH

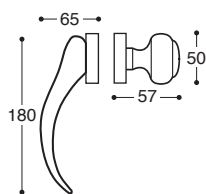

**K0001C**

PZ, Rechts / RH

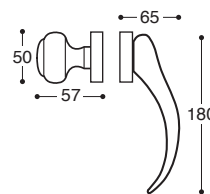

**K000SD**

PZ, Links / LH

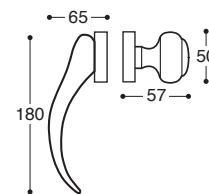

**K000SC**

PZ, Rechts / RH

**Apriti/T11**  
**Metall Rosetten** - Wechselgarnitur

**Apriti/52D**  
**Metall/Kunststoff Rosetten** - Wechselgarnitur

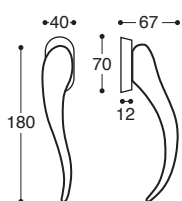

**K0009J**

Links / LH

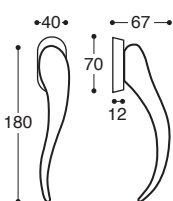

**K0009I**

Rechts / RH

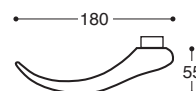

**K00009**

Links / LH

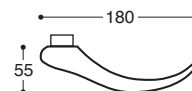

**K00008**

Rechts / RH

**Apriti DK Fenstergriffe** - Mit Rastung  
Window handle - 8 pos. mech.

**Apriti**  
Drückerlochteil - Ohne Rosetten

\* auf Anfrage / on demand

matériau / material  
Aluminium tech  
Techno aluminium



**Apriti.**  
design Philippe Starck

finitions standards / standard finishes



**o6** - Chrome poli  
Polished chrome



**o8** - Chrome satiné  
Satin chrome



**SL** - Silver

finitions trendy / trendy finishes



**G3** - Gun metal



**15** - Noir mat\*  
Mat black\*



**16** - Blanc\*  
White\*



**K0009S**  
BDC / Latch

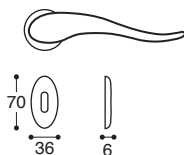

**K0009P**  
Cle L / Lock

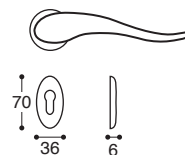

**K0009Y**  
Cle I / Cylinder

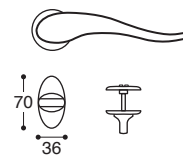

**K0009W**  
Cond/Dec C. 6/7/8 / Privacy

**Apriti Métal et plastique rosace - sans ressort / Metal&plastic rose - without spring**



**K0001S**  
BDC / Latch

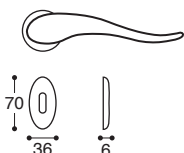

**K0001P**  
Cle L / Lock

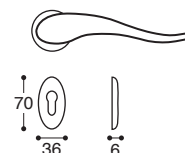

**K0001Y**  
Cle I / Cylinder

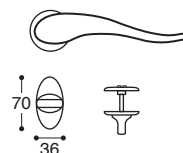

**K0001W**  
Cond/Dec C. 6/7/8 / Privacy

**Apriti/T11 Métal rosace - avec ressort, carré 7 mm / Metal rose - springloaded**



**K000PS**  
BDC / Latch

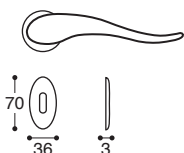

**K000PP**  
Cle L / Lock

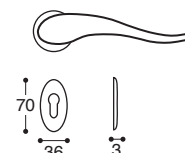

**K000PY**  
Cle I / Cylinder

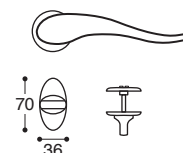

**K000PW**  
Cond/Dec C. 6/7/8 / Privacy

**Apriti/FLT Rosette abaissée métal - avec ressort, carré 7 mm / Metal flat rose - springloaded**

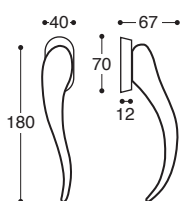

**K0009J**  
Gauche / LH

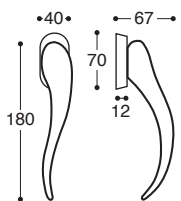

**K0009I**  
Droit / RH

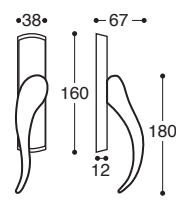

**K0009L**  
Gauche / LH

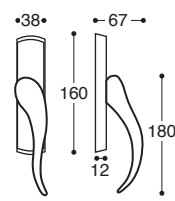

**K0009K**  
Droit / RH

**Apriti DK** Poignée de fenêtre  
Mécan. 8 positions / Window handle - 8 pos. mech.

**Apriti Martellina** Poignée de fenêtre  
Crémone / Window handle - Cremon

\* sur demande / on demand



## Sesamo.

design Philippe Starck

materiale / material  
**Alluminio tecnologico**  
**Techno aluminum**

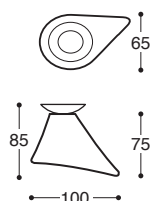

finiture standard / standard finishes



**o6** - Cromo lucido  
 Polished chrome



**o8** - Cromo satinato  
 Satin chrome



**SL** - Silver

finiture trendy / trendy finishes



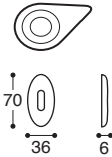
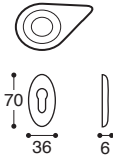
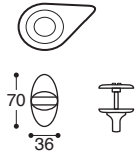

**G3** - Gun metal

  <p><b>K00S90</b> S/bocchetta / Latch</p>	  <p><b>K00S92</b> Patent / Lock</p>	  <p><b>K00S94</b> Yale / Cylinder</p>	  <p><b>K00S96</b> WC / Privacy - Q. 6/7/8</p>
---	---	---	---

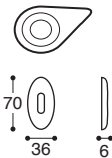
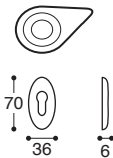
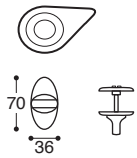
**Sesamo Rosetta metallo&plastica - senza molla / Metal&plastic rose - without spring**

  <p><b>K00S10</b> S/bocchetta / Latch</p>	  <p><b>K00S12</b> Patent / Lock</p>	  <p><b>K00S14</b> Yale / Cylinder</p>	  <p><b>K00S16</b> WC / Privacy - Q. 6/7/8</p>
---	---	---	---

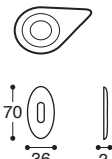
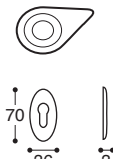
**Sesamo/T11 Rosetta metallo - con molla / Metal rose - springloaded**

  <p><b>K00SP0</b> S/bocchetta / Latch</p>	  <p><b>K00SP2</b> Patent / Lock</p>	  <p><b>K00SP4</b> Yale / Cylinder</p>	  <p><b>K00SP6</b> WC / Privacy - Q. 6/7/8</p>
---	---	---	---

**Sesamo/FLT Rosetta ribassata metallo - con molla / Metal flat rose - springloaded**

Material / material  
Tech-Aluminium  
Techno aluminium



**Sesamo.**  
design Philippe Starck

Standardveredelungen / standard finishes



**o6** - Chrom  
Polished chrome



**o8** - Chrom matt  
Satin chrome



**SL** - Silber  
Silver

Trendy Veredelungen / trendy finishes



**G3** - Gun metal



**K00S10**

Ohne Schlüssel / Latch

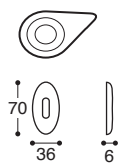

**K00S13**

BB / Lock

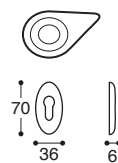

**K00S15**

PZ / Cylinder

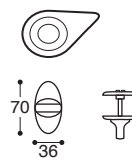

**K00S17**

BAD S. 6/7/8 / Privacy

**Sesamo/T11 Türgriff** - Metall Rosetten DIN 38 mm - Mit Feder / **Metal rose** - springloaded



**K00SS0**

Ohne Schlüssel / Latch

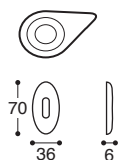

**K00SS3**

BB / Lock

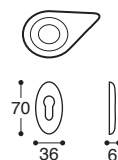

**K00SS5**

PZ / Cylinder



**K00SS7**

BAD S. 6/7/8 / Privacy

**Sesamo/52D Türgriff** - Metall/Kunststoff Rosetten DIN 38 mm - Mit Feder  
**Metal&plastic rose** - springloaded

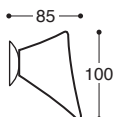

**K00S1D**

PZ, Links / LH

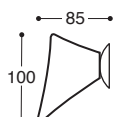

**K00S1C**

PZ, Rechts / RH

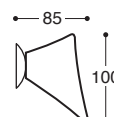

**K00SSD**

PZ, Links / LH

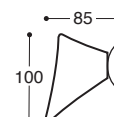

**K00SSC**

PZ, Rechts / RH

**Sesamo/T11**  
Metall Rosetten - Wechselgarnitur

**Sesamo/D52**  
Metall/Kunststoff Rosetten - Wechselgarnitur

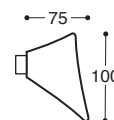

**K00S09**

Links / LH

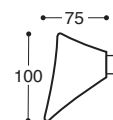

**K00S08**

Rechts / RH

**Sesamo**  
Drückerlochteil - Ohne Rosetten

matériau / material  
Aluminium tech  
Techno aluminium



**Sesamo.**  
design Philippe Starck

finitions standards / standard finishes



**o6** - Chrome poli  
Polished chrome



**o8** - Chrome satiné  
Satin chrome



**SL** - Silver

finitions trendy / trendy finishes



**G3** - Gun metal

<b>K00S9S</b> BDC / Latch	<b>K00S9P</b> Cle L / Lock	<b>K00S9Y</b> Cle I / Cylinder	<b>K00S9W</b> Cond/Dec C. 6/7/8 / Privacy

**Sesamo Métal et plastique rosace - sans ressort, carré 7 mm / Metal&plastic rose - without spring**

<b>K00S1S</b> BDC / Latch	<b>K00S1P</b> Cle L / Lock	<b>K00S1Y</b> Cle I / Cylinder	<b>K00S1W</b> Cond/Dec C. 6/7/8 / Privacy

**Sesamo/T11 Métal rosace - avec ressort, carré 7 mm / Metal rose - springloaded**

<b>K00SPS</b> BDC / Latch	<b>K00SPP</b> Cle L / Lock	<b>K00SPY</b> Cle I / Cylinder	<b>K00SPW</b> Cond/Dec C. 6/7/8 / Privacy

**Sesamo/FLT Rosette abaissée métal - avec ressort, carré 7 mm / Metal flat rose - springloaded**

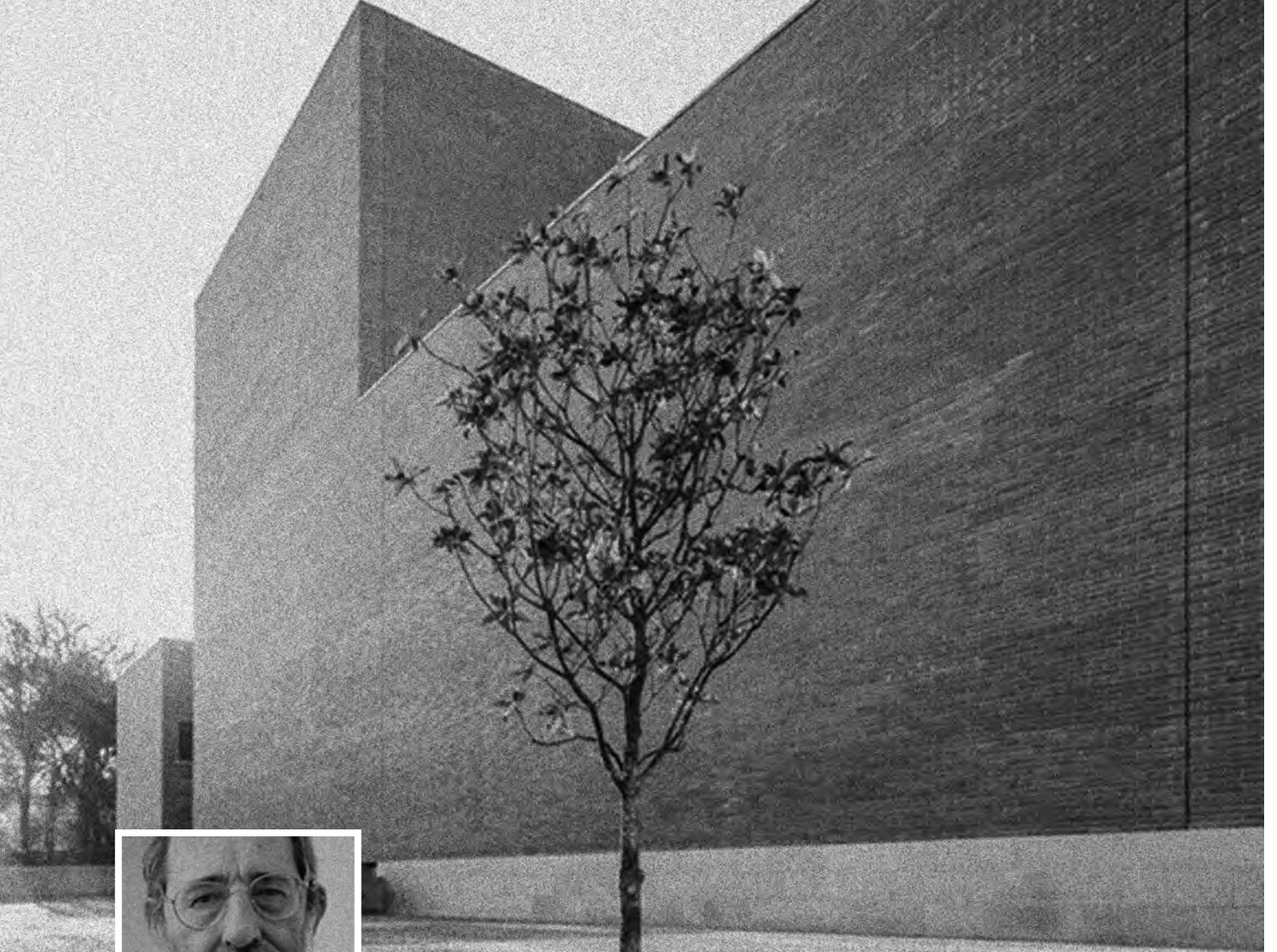

Auditorium Teatral de Llinars del Vallès, Llinars del Vallès, Barcellona, Spagna 2015

**ALVARO SIZA VIEIRA**  
ARCHITETTO

Nato a Motosinhos (Porto) nel 1933. Dalla fine degli anni 50 opera con il proprio studio professionale a Porto. Ha realizzato molte opere prestigiose tra le quali il Padiglione portoghese dell'Expo di Lisbona '98 e il Museo d'Arte Contemporanea di Santiago di Compostela. Le sue opere sono state esposte in ogni parte del mondo, alla Biennale di Venezia, alla Triennale di Milano, al Centre Georges Pompidou di Parigi, al Museo d'Architettura di Helsinki, in Germania, in Inghilterra, Brasile, Stati Uniti. Ha ricevuto numerosi e importanti riconoscimenti e premi internazionali, tra i quali il premio Mies van der Rohe, la medaglia d'oro della Fondazione Alvar Aalto, l'Arold W. Brunner Memorial Prize, il Pritzker Prize, il Praemium Imperiale.

Born in Motosinhos (Porto) in 1933. Since the late 1950's, he has been working with his own professional studio in

Porto. He has performed many prestigious works including The Portuguese Pavilion at Expo Lisbon in '98 and the Museum of Contemporary Art of Santiago de Compostela. His works have been exhibited all over the world, the Venice Biennale, the Milan Triennale, the Georges Pompidou Center in Paris, the Architecture Museum of Helsinki, Germany, England, Brazil, the United States. He has received numerous important awards and international prizes including the Mies van der Rohe prize, the Gold Medal of the Alvar Aalto Foundation, the Arold W. Brunner Memorial Prize, the Pritzker Prize, the Imperial Praemium.

1933 in Motosinhos (Porto) geboren. Seit Ende der 50er-Jahre arbeitet er in seinem eigenen Studio in Porto. Er hat mehrere renommierte Werke erschaffen, darunter der portugiesische Pavillon auf der Expo 1998 in Lissabon und das Museum für moderne

Kunst in Santiago di Compostela. Seine Werke wurden bereits auf der ganzen Welt ausgestellt, von der Biennale in Wien, zur Triennale in Mailand bis hin zum Centre Georges Pompidou in Paris, dem Architekturmuseum in Helsinki, Deutschland, England, Brasilien und den Vereinigten Staaten. Er hat zahlreiche wichtige Auszeichnungen und internationale Preise erhalten, darunter der Mies van der Rohe Preis, die goldene Medaille der Alvar Aalto Stiftung, den Arold W. Brunner Memorial Prize, den Pritzker Prize, den Praemium Imperiale.

Né à Motosinhos (Porto) en 1933. A partir de la fin des années 50, il travaille avec son cabinet professionnel à Porto. Il a réalisé de nombreuses œuvres prestigieuses parmi lesquelles le Pavillon portugais de l'Expo de Lisbonne 1998 et le Musée d'Art Contemporain de Santiago de Compostelle. Ses œuvres ont été exposées

partout dans le monde, à la Biennale de Venise, à la Triennale de Milan, au Centre Georges Pompidou de Paris, au Musée d'Architecture d'Helsinki, en Allemagne, en Angleterre, au Brésil, États-Unis. Il a reçu de nombreuses reconnaissances et prix internationaux, parmi lesquels le prix Mies van der Rohe, la médaille d'or de la Fondation Alvar Aalto, l'Arold W. Brunner Memorial Prize, le prix Pritzker, le Praemium Impérial.



KLEIS



**Calliope.**

1993



## Calliope.

design Alvaro Siza Vieira

materiale / material  
Ottone / Brass

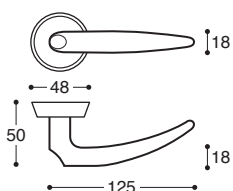

finiture standard / standard finishes



**00** - Oro  
Polished brass



**06** - Cromo lucido  
Polished chrome



**08** - Cromo satinato  
Satin chrome

finiture trendy / trendy finishes



**G3** - Gun metal



**15** - Nero opaco\*  
Mat black\*

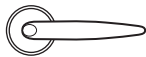
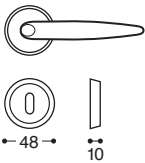
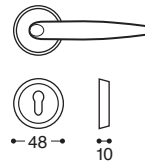
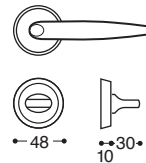

**16** - Bianco\*  
White\*

 <p><b>K00440</b> S/bocchetta / Latch</p>	 <p><b>K00442</b> Patent / Lock</p>	 <p><b>K00444</b> Yale / Cylinder</p>	 <p><b>K00446</b> WC / Privacy - Q. 6/7/8</p>
--	--	--	--

**Calliope/HB11** Rosetta metallo&plastica - con molla / **Metal&plastic rose** - springloaded

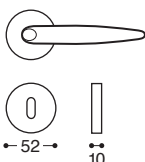
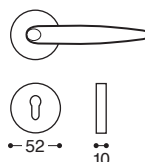
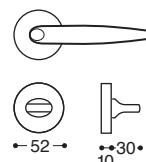
 <p><b>K00410</b> S/bocchetta / Latch</p>	 <p><b>K00412</b> Patent / Lock</p>	 <p><b>K00414</b> Yale / Cylinder</p>	 <p><b>K00416</b> WC / Privacy - Q. 6/7/8</p>
--	--	--	--

**Calliope/T11** Rosetta metallo - con molla / **Metal rose** - springloaded

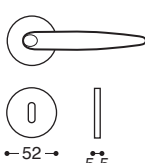
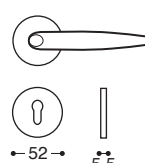
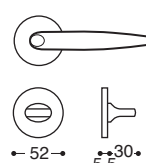
 <p><b>K004P0</b> S/bocchetta / Latch</p>	 <p><b>K004P2</b> Patent / Lock</p>	 <p><b>K004P4</b> Yale / Cylinder</p>	 <p><b>K004P6</b> WC / Privacy - Q. 6/7/8</p>
--	--	--	--

**Calliope/FLT** Rosetta ribassata metallo - con molla / **Metal flat rose** - springloaded

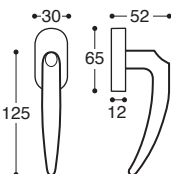
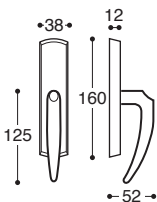
 <p><b>K00441</b> Senza mano / Without hand</p>	 <p><b>K0044K</b> Senza mano / Without hand</p>
--	--

**Calliope DK** - mov. 8 scatti  
Window handle - 8 pos. mech.

**Calliope Martellina**  
Per finestra - Cremonese / For window - Cremon

\* a richiesta / on demand

Material / material  
Messing / Brass



**Calliope.**  
design Alvaro Siza Vieira

Standardveredelungen / standard finishes



**00** - Messing poliert  
Polished brass



**06** - Chrom  
Polished chrome



**08** - Chrom matt  
Satin chrome

Trendy Veredelungen / trendy finishes



**G3** - Gun metal



**15** - Matt schwarz\*  
Mat black\*



**16** - Weiß\*  
White\*

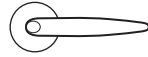

**K00410**

Ohne Schlüssel / Latch

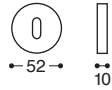
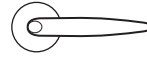

**K00413**

BB / Lock

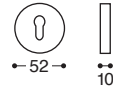
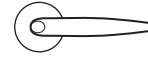

**K00415**

PZ / Cylinder

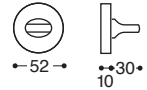
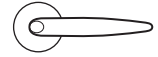

**K00417**

BAD S. 6/7/8 / Privacy

**Calliope/T11 Türgriff** - Metall Rosetten DIN 38 mm - Mit Feder / **Metal rose** - springloaded

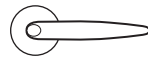

**K004S0**

Ohne Schlüssel / Latch

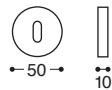
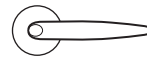

**K004S3**

BB / Lock

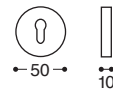
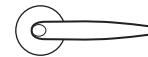

**K004S5**

PZ / Cylinder

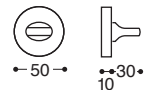
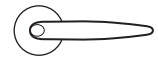

**K004S7**

BAD S. 6/7/8 / Privacy

**Calliope/52D Türgriff** - Metall/Kunststoff Rosetten DIN 38 mm - Mit Feder  
**Metal&plastic rose** - springloaded

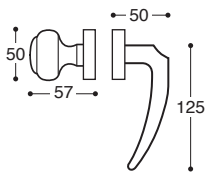

**K0041D**

PZ, Links / LH

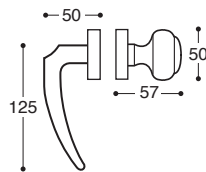

**K0041C**

PZ, Rechts / RH

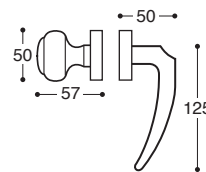

**K004SD**

PZ, Links / LH

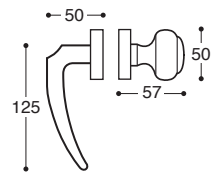

**K004SC**

PZ, Rechts / RH

**Calliope/T11**  
Metall Rosetten - Wechselgarnitur

**Calliope/52D**  
Metall/Kunststoff Rosetten - Wechselgarnitur

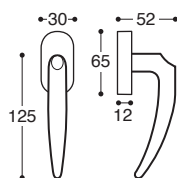

**K00441**

Ohne Hand / Without hand

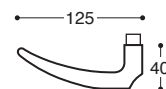

**K00409**

Links / LH

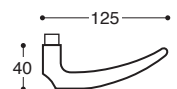

**K00408**

Rechts / RH

**Calliope DK** Fenstergriffe - Mit Rastung  
Window handle - 8 pos. mech.

**Calliope**  
Drückerlochteil - Ohne Rosetten

\* auf Anfrage / on demand

matériau / material  
Laiton / Brass

standard 

**Calliope.**  
design Alvaro Siza Vieira

finitions standards / standard finishes



**00** - Laiton poli  
Polished brass



**06** - Chrome poli  
Polished chrome



**08** - Chrome satiné  
Satin chrome

finitions trendy / trendy finishes



**G3** - Gun metal



**15** - Noir mat\*  
Mat black\*



**16** - Blanc\*  
White\*



**K0044S**  
BDC / Latch



**K0044P**  
Cle L / Lock



**K0044Y**  
Cle I / Cylinder



**K0044W**  
Cond/Dec C. 6/7/8 / Privacy

**Calliope/HB11** Métal et plastique rosace - avec ressort, carré 7 mm / **Metal&plastic rose** - springloaded



**K0041S**  
BDC / Latch



**K0041P**  
Cle L / Lock



**K0041Y**  
Cle I / Cylinder



**K0041W**  
Cond/Dec C. 6/7/8 / Privacy

**Calliope/T11** Métal rosace - avec ressort, carré 7 mm / **Metal rose** - springloaded



**K004PS**  
BDC / Latch



**K004PP**  
Cle L / Lock



**K004PY**  
Cle I / Cylinder



**K004PW**  
Cond/Dec C. 6/7/8 / Privacy

**Calliope/FLT** Rosette abaissée métal - avec ressort, carré 7 mm / **Metal flat rose** - springloaded

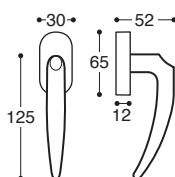

**K0044I**  
Sans main / Without hand

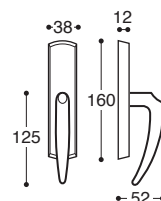

**K0044K**  
Sans main / Without hand

**Calliope DK** Poignée de fenêtre  
Mécan. 8 positions / Window handle - 8 pos. mech.

**Calliope Martellina** Poignée de fenêtre  
Crémone / Window handle - Cremon

\* sur demande / on demand

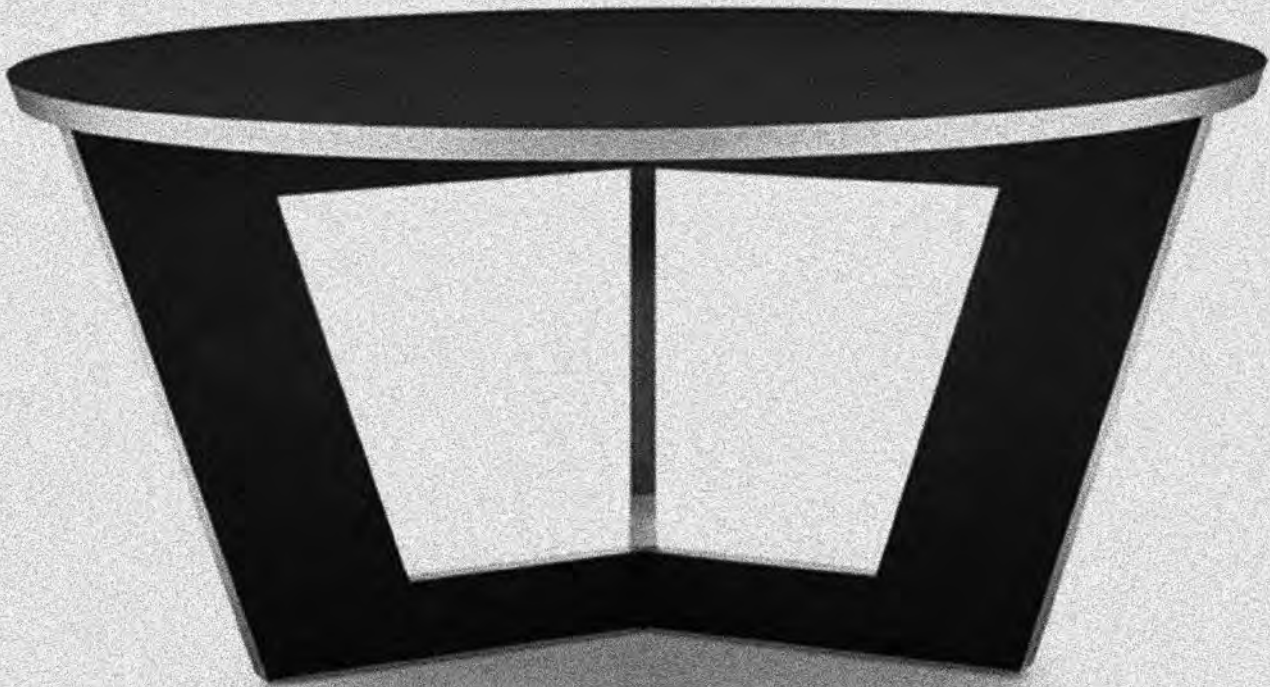

Tika 1999



**HANNES WETTSTEIN**  
DESIGNER

Nato in Svizzera nel 1958, inizia la carriera lavorando freelance prima di diventare socio nel Eclat Design Agency. Nel 1993 è co-fondatore di 9D Design. Insegna ed è titolare di cattedra dal 1994 all'Academy of Design in Karlsruhe. Si occupa della progettazione di prodotti, immagini aziendali, interni e architettura. Ha vinto molti premi e commissioni di rilievo, come ad esempio l'Ambasciata svizzera a Teheran e il Grand Hyatt Hotel di Berlino. La sua clientela comprende anche Cassina, UMS Pastoe, Shimano, Baleri Italia e Artemide.

Born in Switzerland in 1958, he began his career as a freelancer before becoming a partner of Eclat Design Agency. In 1993 he cofounded 9D Design. He teaches at the Academy of Design in Karlsruhe, where he has held a professorship since 1994. His specializations are product design, corporate image, architecture and interior design. He has won

many prizes and received many prestigious commissions, such as the Swiss Embassy in Teheran and the Grand Hyatt Hotel in Berlin. His clientele includes Cassina, UMS Pastoe, Shimano, Baleri Italia and Artemide.

1958 in der Schweiz geboren beginnt er seine Karriere als Freelancer bevor er Partner bei der Eclat Design Agency wird. 1993 ist er Mitgründer von 9D Design. Er beginnt seine Lehrtätigkeit und ist ab 1994 Inhaber des Lehrstuhls an der Academy of Design in Karlsruhe. Er gestaltet Produkte, Unternehmensbilder, interne Ausstattungen und Architektur. Er gewann viele Preise und wichtige Aufträge, wie z.B. die schweizer Botschaft in Teheran und das Grand Hyatt Hotel in Berlino. Zu seiner Kundschaft gehören auch Cassina, UMS Pastoe, Shimano, Baleri Italia und Artemide.

Né en Suisse en 1958, il commence sa carrière en travaillant comme indépendant avant de devenir partenaire dans l'Eclat Design Agency. En 1993, il est cofondateur de 9D Design. Il enseigne mais aussi est professeur titulaire de la chaire depuis 1994, à l'Academy of Design de Karlsruhe. Il s'occupe de la conception de produits, d'images d'entreprises, de design d'intérieur et d'architecture. Il a gagné beaucoup de prix et travaux importants, comme par exemple l'Ambassade suisse à Téhéran et le Grand Hyatt Hotel de Berlin. Sa clientèle comprend également Cassina, UMS Pastoe, Shimano, Baleri Italia et Artemide.



**Cut.**

2005

**Sinn.**

1991



**Cut.**  
design Hannes Wettstein

materiale / material  
**Alluminio tecnologico**  
Techno aluminum

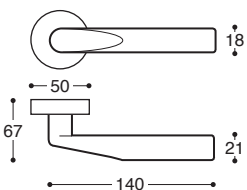

finiture standard / standard finishes



**o6** - Cromo lucido  
Polished chrome



**o8** - Cromo satinato  
Satin chrome



**SL** - Silver

finiture trendy / trendy finishes



**G3** - Gun metal



**15** - Nero opaco\*  
Mat black\*



**16** - Bianco\*  
White\*

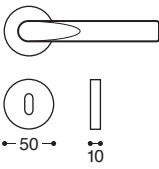
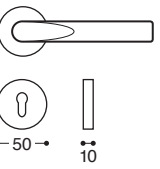
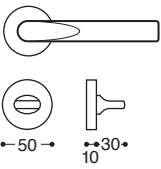

 <p><b>K00E60</b> S/bocchetta / Latch</p>	 <p><b>K00E62</b> Patent / Lock</p>	 <p><b>K00E64</b> Yale / Cylinder</p>	 <p><b>K00E66</b> WC / Privacy - Q. 6/7/8</p>
--	--	--	--

**Cut/HB14 Rosetta metallo&plastica - con molla / Metal&plastic rose - springloaded**

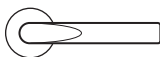
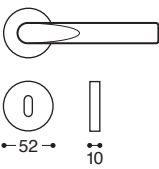
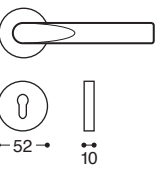
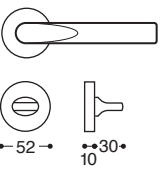
 <p><b>K00E10</b> S/bocchetta / Latch</p>	 <p><b>K00E12</b> Patent / Lock</p>	 <p><b>K00E14</b> Yale / Cylinder</p>	 <p><b>K00E16</b> WC / Privacy - Q. 6/7/8</p>
--	--	--	--

**Cut/T11 Rosetta metallo - con molla / Metal rose - springloaded**

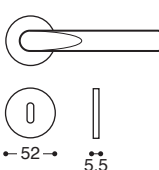
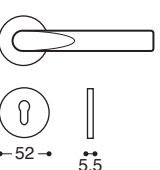
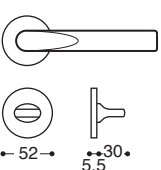
 <p><b>K00EP0</b> S/bocchetta / Latch</p>	 <p><b>K00EP2</b> Patent / Lock</p>	 <p><b>K00EP4</b> Yale / Cylinder</p>	 <p><b>K00EP6</b> WC / Privacy - Q. 6/7/8</p>
--	--	--	--

**Cut/FLT Rosetta ribassata metallo - con molla / Metal flat rose - springloaded**

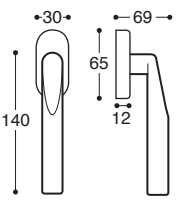
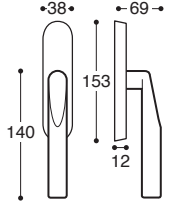
 <p><b>K00E61</b> Senza mano / Without hand</p>	 <p><b>K00E6K</b> Senza mano / Without hand</p>
--	--

**Cut DK - mov. 8 scatti**  
Window handle - 8 pos. mech.

**Cut Martellina**  
Per finestra - Cremonese / For window - Cremon

\* a richiesta / on demand

Material / material  
Tech-Aluminium  
Techno aluminum



**Cut.**  
design Hannes Wettstein

Standardveredelungen / standard finishes



**o6** - Chrom  
Polished chrome



**o8** - Chrom matt  
Satin chrome



**SL** - Silber  
Silver

Trendy Veredelungen / trendy finishes



**G3** - Gun metal



**15** - Matt schwarz\*  
Mat black\*



**16** - Weiß\*  
White\*



**K00E10**

Ohne Schlüssel / Latch



**K00E13**

BB / Lock

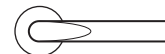

**K00E15**

PZ / Cylinder

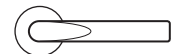

**K00E17**

BAD S. 6/7/8 / Privacy

**Cut/T11 Türgriff** - Metall Rosetten DIN 38 mm - Mit Feder / **Metal rose** - springloaded



**K00E50**

Ohne Schlüssel / Latch



**K00E53**

BB / Lock



**K00E55**

PZ / Cylinder



**K00E57**

BAD S. 6/7/8 / Privacy

**Cut/52D Türgriff** - Metall/Kunststoff Rosetten DIN 38 mm - Mit Feder  
**Metal&plastic rose** - springloaded

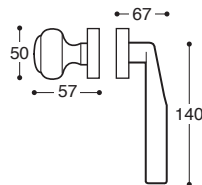

**K00E1D**

PZ, Links / LH

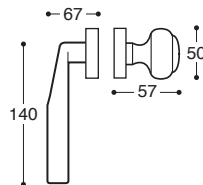

**K00E1C**

PZ, Rechts / RH

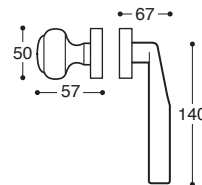

**K00ESD**

PZ, Links / LH

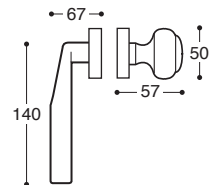

**K00ESC**

PZ, Rechts / RH

**Cut/T11**  
**Metall Rosetten** - Wechselgarnitur

**Cut/D52**  
**Metall/Kunststoff Rosetten** - Wechselgarnitur

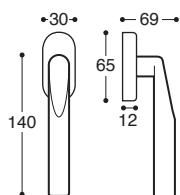

**K00E61**

Ohne Hand / Without hand

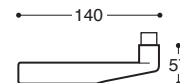

**K00E09**

Links / LH

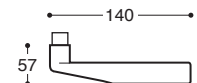

**K00E08**

Rechts / RH

**Cut DK** Fenstergriffe - Mit Rastung  
Window handle - 8 pos. mech.

**Cut**  
Drückerlochteil - Ohne Rosetten

\* auf Anfrage / on demand

matériau / material  
Aluminium tech  
Techno aluminium

standard 

**Cut.**  
design Hannes Wettstein

finitions standards / standard finishes



**o6** - Chrome poli  
Polished chrome



**o8** - Chrome satiné  
Satin chrome



**SL** - Silver

finitions trendy / trendy finishes



**G3** - Gun metal



**15** - Noir mat\*  
Mat black\*



**16** - Blanc\*  
White\*



**K00E6S**  
BDC / Latch

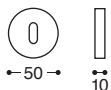
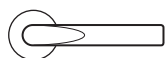

**K00E6P**  
Cle L / Lock

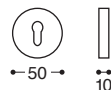

**K00E6Y**  
Cle I / Cylinder

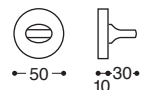
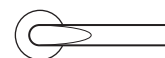

**K00E6W**  
Cond/Dec C. 6/7/8 / Privacy

**Cut/HB14 Métal et plastique rosace - avec ressort, carré 7 mm / Metal&plastic rose - springloaded**



**K00E1S**  
BDC / Latch

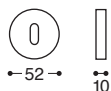

**K00E1P**  
Cle L / Lock

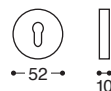
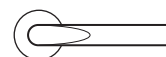

**K00E1Y**  
Cle I / Cylinder

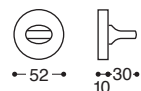
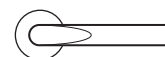

**K00E1W**  
Cond/Dec C. 6/7/8 / Privacy

**Cut/T11 Métal rosace - avec ressort, carré 7 mm / Metal rose - springloaded**

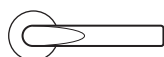

**K00EPS**  
BDC / Latch

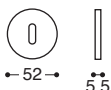

**K00EPP**  
Cle L / Lock

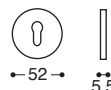

**K00EPY**  
Cle I / Cylinder

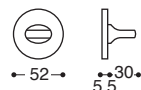

**K00EPW**  
Cond/Dec C. 6/7/8 / Privacy

**Cut/FLT Rosette abaissée métal - avec ressort, carré 7 mm / Metal flat rose - springloaded**

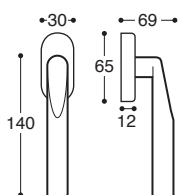

**K00E6I**  
Sans main / Without hand

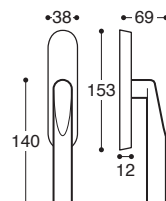

**K00E6K**  
Sans main / Without hand

**Cut DK Poignée de fenêtre**  
Mécan. 8 positions / Window handle - 8 pos. mech.

**Cut Martellina Poignée de fenêtre**  
Crémone / Window handle - Cremon

\* sur demande / on demand



**Sinn.**  
design Hannes Wettstein

materiale / material  
**Ottone / Brass**

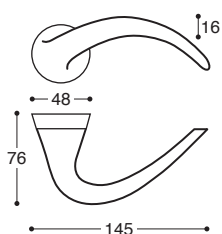

finiture standard / standard finishes



**00** - Oro  
Polished brass



**06** - Cromo lucido  
Polished chrome



**08** - Cromo satinato  
Satin chrome

finiture trendy / trendy finishes









**G3** - Gun metal





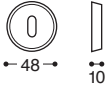

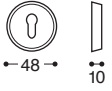

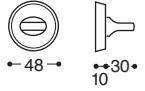
**15** - Nero opaco\*  
Mat black\*

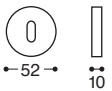

**16** - Bianco\*  
White\*

 <b>K00140</b> S/bocchetta / Latch	  <b>K00142</b> Patent / Lock	  <b>K00144</b> Yale / Cylinder	  <b>K00146</b> WC / Privacy - Q. 6/7/8
---	--	--	--

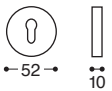
**Sinn/HB11 Rosetta metallo&plastica - con molla / Metal&plastic rose - springloaded**

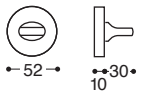
 <b>K00110</b> S/bocchetta / Latch	  <b>K00112</b> Patent / Lock	  <b>K00114</b> Yale / Cylinder	  <b>K00116</b> WC / Privacy - Q. 6/7/8
---	--	--	--

**Sinn/T11 Rosetta metallo - con molla / Metal rose - springloaded**

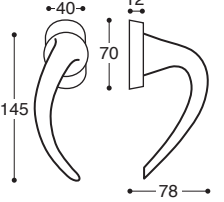
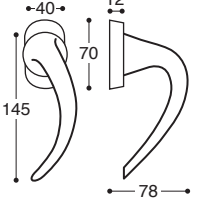
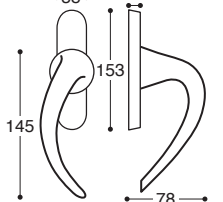
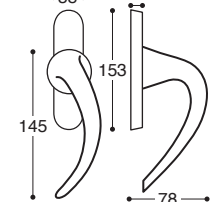
 <b>K0014J</b> SX / LH	 <b>K0014I</b> DX / RH	 <b>K0014L</b> SX / LH	 <b>K0014K</b> DX / RH
---	---	--	---

**Sinn DK - mov. 8 scatti**  
Window handle - 8 pos. mech.

**Sinn Martellina**  
Per finestra - Cremonese / For window - Cremon

\* a richiesta / on demand

Material / material  
Messing / Brass



**Sinn.**  
design Hannes Wettstein

Standardveredelungen / standard finishes



**00** - Messing poliert  
Polished brass



**06** - Chrom  
Polished chrome



**08** - Chrom matt  
Satin chrome

Trendy Veredelungen / trendy finishes



**G3** - Gun metal



**15** - Matt schwarz\*  
Mat black\*



**16** - Weiß\*  
White\*



**K00110**

Ohne Schlüssel / Latch

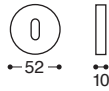

**K00113**

BB / Lock

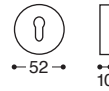

**K00115**

PZ / Cylinder

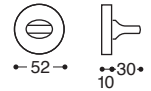

**K00117**

BAD S. 6/7/8 / Privacy

**Sinn/T11 Türgriff** - Metall Rosetten DIN 38 mm - Mit Feder / **Metal rose** - springloaded



**K001S0**

Ohne Schlüssel / Latch

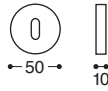

**K001S3**

BB / Lock

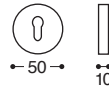

**K001S5**

PZ / Cylinder

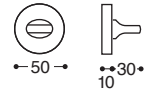

**K001S7**

BAD S. 6/7/8 / Privacy

**Sinn/52D Türgriff** - Metall/Kunststoff Rosetten DIN 38 mm - Mit Feder  
**Metal&plastic rose** - springloaded

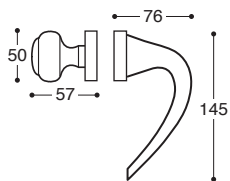

**K0011D**

PZ, Links / LH

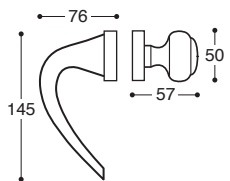

**K0011C**

PZ, Rechts / RH

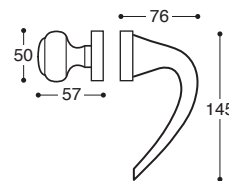

**K001SD**

PZ, Links / LH

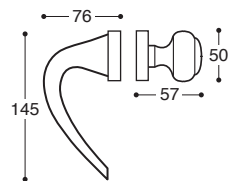

**K001SC**

PZ, Rechts / RH

**Sinn/T11**  
**Metall Rosetten** - Wechselgarnitur

**Sinn/52D**  
**Metall/Kunststoff Rosetten** - Wechselgarnitur

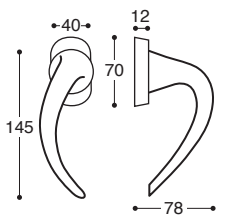

**K0014J**

Links / LH

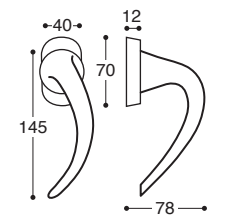

**K0014I**

Rechts / RH

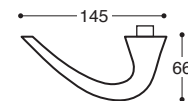

**K00109**

Links / LH

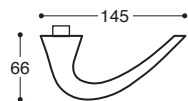

**K00108**

Rechts / RH

**Sinn DK** Fenstergriffe - Mit Rastung  
Window handle - 8 pos. mech.

**Sinn**  
Drückerlochteil - Ohne Rosetten

\* auf Anfrage / on demand

matériau / material  
Laiton / Brass

standard 

**Sinn.**  
design Hannes Wettstein

finitions standards / standard finishes



**00** - Laiton poli  
Polished brass



**06** - Chrome poli  
Polished chrome



**08** - Chrome satiné  
Satin chrome

finitions trendy / trendy finishes



**G3** - Gun metal



**15** - Noir mat\*  
Mat black\*



**16** - Blanc\*  
White\*



**K0014S**  
BDC / Latch

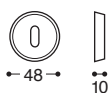

**K0014P**  
Cle L / Lock

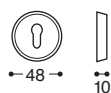

**K0014Y**  
Cle I / Cylinder

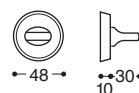

**K0014W**  
Cond/Dec C. 6/7/8 / Privacy

**Sinn/HB11 Métal et plastique rosace - avec ressort, carré 7 mm / Metal&plastic rose - springloaded**



**K0011S**  
BDC / Latch

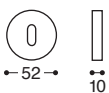

**K0011P**  
Cle L / Lock

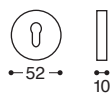

**K0011Y**  
Cle I / Cylinder

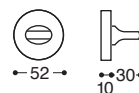

**K0011W**  
Cond/Dec C. 6/7/8 / Privacy

**Sinn/T11 Métal rosace - avec ressort, carré 7 mm / Metal rose - springloaded**

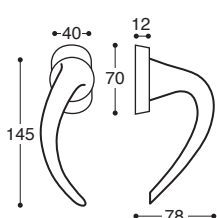

**K0014J**  
Gauche / LH

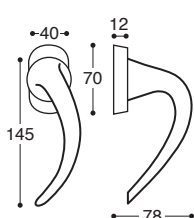

**K0014I**  
Droite / RH

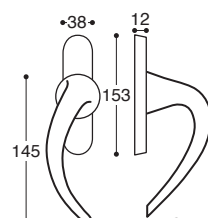

**K0014L**  
Gauche / LH

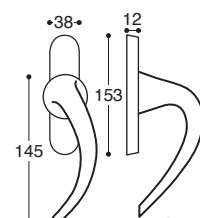

**K0014K**  
Droite / RH

**Sinn DK Poignée de fenetre**  
Mécan. 8 positions / Window handle - 8 pos. mech.

**Sinn Martellina Poignée de fenetre**  
Crémone / Window handle - Cremon

\* sur demande / on demand



Mimi 1991

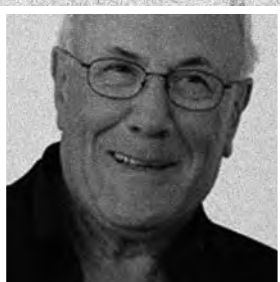

**ENRICO BALERI**  
DESIGNER

Enrico Baleri nasce a Albino (Bergamo) nel 1942. Negli anni sessanta e settanta progetta mobili, lampade e oggetti per Gavina, Flos, Knoll International e Alias, azienda che costituisce nel 1979 nella quale, fino al 1983, svolge il ruolo di direttore artistico. Nel 1984 con Marilisa Baleri Decimo fonda Baleri Italia e collabora con Hollein, Mendini e con gli esordienti Starck, Dalisi, Wettstein e altri alla formazione di una collezione unitaria. Nel 1994 fonda Gloria Srl per la quale progetta alcuni prodotti di successo. Dal 2004 è art director di eb&c Centro Ricerche Enrico Baleri e svolge attività nel mondo della comunicazione, dell'architettura, e del disegno industriale collaborando con industrie internazionali tra cui Baleri Italia.

Enrico Baleri was born in Albino (Bergamo) in 1942. In the sixties and seventies he designed furniture, lamps and objects for Gavina, Flos, Knoll International

and Alias, a company that he founded in 1979 and in which, until 1983, he held the role of artistic director. In 1984 with Marilisa Baleri Decimo founded Baleri Italia and collaborated with Hollein, Mendini and with the newcomers Starck, Dalisi, Wettstein and others in the formation of a unitary collection. Since 2004 he has been an art director of Enrico Baleri's Research Center and he has been active in the world of communication, architecture and industrial design, working with international industries including Baleri Italia.

Enrico Baleri wurde 1942 in Albino (Bergamo) geboren. In den 60er- und 70er-Jahren entwirft er Möbel, Objekte für Gavina, Flos, Knoll International und Alias, ein Unternehmen, das er 1979 gründet und in dem er bis 1983 als künstlerischer Leiter wirkt. 1984 gründet er mit Marilisa Baleri Decimo das Unternehmen Baleri Italia und arbeitet mit Hollein, Mendini und den Neueinsteigern Starck,

Dalisi, Wettstein und anderen an der Entwicklung einer gemeinsamen Kollektion. 1994 gründet er Gloria Srl für das er einige erfolgreiche Produkte entwirft. Seit 2004 ist er Art Director bei eb&c Centro Ricerche Enrico Baleri und ist im Bereich der Kommunikation, Architektur, Industriedesign tätig und arbeitet mit internationalen Industrien zusammen, unter anderem mit Baleri Italia.

Enrico Baleri est né à Albino (Bergame) en 1942. Dans les années soixante et soixante-dix il conçoit des meubles, des lampes et des objets pour Gavina, Flos, Knoll International et Alias, entreprise qu'il créait en 1979 dans laquelle, il exerce la fonction jusqu'en 1983 de directeur artistique. En 1984 avec Marilisa Baleri Decimo il fonde Baleri Italia et collabore avec Hollein, Mendini et avec les débutants Starck, Dalisi, Wettstein et d'autres à la création d'une collection unique. En 1994 il fonde Gloria

Srl pour laquelle il conçoit plusieurs produits à succès. A partir de 2004 il est directeur artistique de eb&c Centre de recherches Enrico Baleri et accomplit des activités dans le monde de la communication, de l'architecture, et du dessin industriel en collaborant avec des industries internationales parmi lesquelles Baleri Italia.





**Fedra.**

1993

**Fedra 2005.**

2005



**Fedra.**  
design Enrico Baleri

materiale / material  
Policarbonato / Polycarbonate

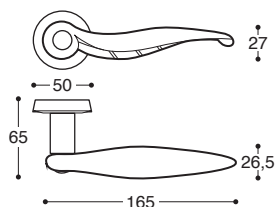

finiture standard / standard finishes



**17 - Rosso**  
Red



**20 - Nero**  
Black



**16 - Bianco**  
White



**19 - Verde**  
Green



**K00580**  
S/bocchetta / Latch

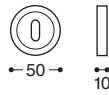

**K00582**  
Patent / Lock

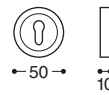

**K00584**  
Yale / Cylinder

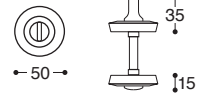

**K00586**  
WC / Privacy - Q.6/7/8

**Fedra Maniglia** - con molla / **Doorhandle** - springloaded

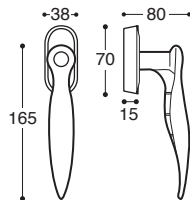

**K00581**  
Senza mano / Without hand

**Fedra DK** - mov. 8 scatti  
Window handle - 8 pos. mech.

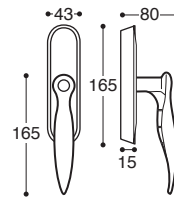

**K0058K**  
Senza mano / Without hand

**Fedra Martellina**  
Per finestra - Cremonese / For window - Cremon

Material / material  
Polycarbonat / Polycarbonate

standard 

**Fedra.**  
design Enrico Baleri

Standardveredelungen / standard finishes



**17 - Rot**  
Red



**16 - Weiß**  
White



**19 - Grün**  
Green



**20 - Schwarz**  
Black



**K00581**

Ohne Schlüssel / Latch

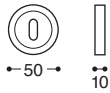

**K00583**

BB / Lock

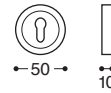

**K00585**

PZ / Cylinder

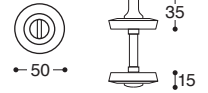

**K00587**

BAD S. 6/7/8 / Privacy

**Fedra Türgriff - Rosetten - Mit Feder / Doorhandle - springloaded**

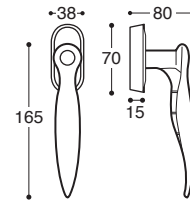

**K00581**

Ohne Hand / Without hand

**Fedra DK Fenstergriffe - Mit Rastung**  
Window handle - 8 pos. mech.

matériau / material  
Polycarbonate

standard 

**Fedra.**  
design Enrico Baleri

finitions standards / standard finishes



**17 - Rouge**  
Red



**16 - Blanc**  
White



**19 - Vert**  
Green



**20 - Noir**  
Black



**K0058S**  
BDC / Latch

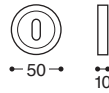

**K0058P**  
Cle L / Lock

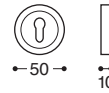

**K0058Y**  
Cle I / Cylinder

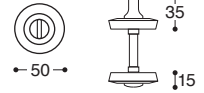

**K0058W**  
Cond/Dec C. 6/7/8 / Privacy

**Fedra Poignée de porte** - avec ressort, carré 7 mm / **Doorhandle** - springloaded

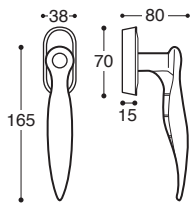

**K0058I**  
Sans main / Without hand

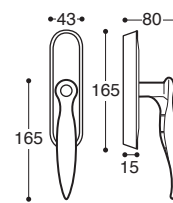

**K0058K**  
Sans main / Without hand

**Fedra DK Poignée de fenetre**  
Mécan. 8 positions / Window handle - 8 pos. mech.

**Fedra Martellina Poignée de fenetre**  
Crémone / Window handle - Cremon



## Fedra 2005.

design Enrico Baleri

materiale / material  
**Alluminio tecnologico**  
**Techno aluminum**

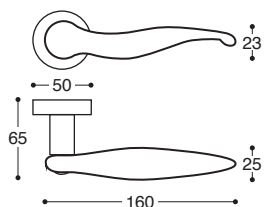

finiture standard / standard finishes



**o6** - Cromo lucido  
 Polished chrome



**o8** - Cromo satinato  
 Satin chrome



**SL** - Silver

finiture trendy / trendy finishes









**G3** - Gun metal





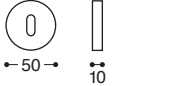

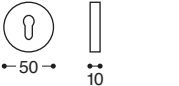

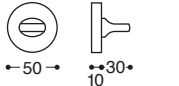
**15** - Nero opaco\*  
 Mat black\*





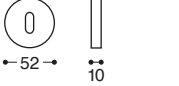

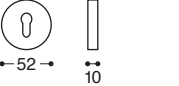

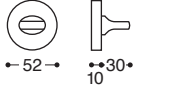
**16** - Bianco\*  
 White\*

 	 	 	 
<p><b>K00560</b> S/bocchetta / Latch</p>	<p><b>K00562</b> Patent / Lock</p>	<p><b>K00564</b> Yale / Cylinder</p>	<p><b>K00566</b> WC / Privacy - Q. 6/7/8</p>

**Fedra2005/HB14 Rosetta metallo&plastica - con molla / Metal&plastic rose - springloaded**

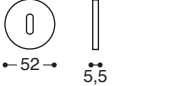
 	 	 	 
<p><b>K00510</b> S/bocchetta / Latch</p>	<p><b>K00512</b> Patent / Lock</p>	<p><b>K00514</b> Yale / Cylinder</p>	<p><b>K00516</b> WC / Privacy - Q. 6/7/8</p>

**Fedra2005/T11 Rosetta metallo - con molla / Metal rose - springloaded**

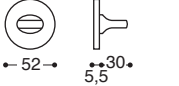
 	 	 	 
<p><b>K005P0</b> S/bocchetta / Latch</p>	<p><b>K005P2</b> Patent / Lock</p>	<p><b>K005P4</b> Yale / Cylinder</p>	<p><b>K005P6</b> WC / Privacy - Q. 6/7/8</p>

**Fedra2005/FLT Rosetta ribassata metallo - con molla / Metal flat rose - springloaded**

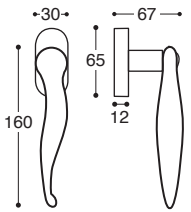
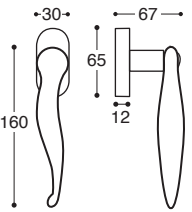
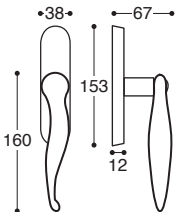
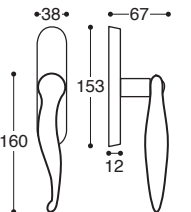
			
<p><b>K0056J</b> SX / LH</p>	<p><b>K0056I</b> DX / RH</p>	<p><b>K0056L</b> SX / LH</p>	<p><b>K0056K</b> DX / RH</p>

**Fedra2005 DK - mov. 8 scatti**  
Window handle - 8 pos. mech.

**Fedra2005 Martellina**  
Per finestra - Cremonese / For window - Cremon

\* a richiesta / on demand

Material / material  
Tech-Aluminium  
Techno aluminium



**Fedra 2005.**  
design Enrico Baleri

Standardveredelungen / standard finishes



**o6** - Chrom  
Polished chrome



**o8** - Chrom matt  
Satin chrome



**SL** - Silber  
Silver

Trendy Veredelungen / trendy finishes



**G3** - Gun metal



**15** - Matt schwarz\*  
Mat black\*



**16** - Weiß\*  
White\*



**K00510**

Ohne Schlüssel / Latch



**K00513**

BB / Lock



**K00515**

PZ / Cylinder



**K00517**

BAD S. 6/7/8 / Privacy

**Fedra2005/T11** Türgriff - Metall Rosetten DIN 38 mm - Mit Feder / **Metal rose** - springloaded



**K005S0**

Ohne Schlüssel / Latch



**K005S3**

BB / Lock



**K005S5**

PZ / Cylinder



**K005S7**

BAD S. 6/7/8 / Privacy

**Fedra2005/52D** Türgriff - Metall/Kunststoff Rosetten DIN 38 mm - Mit Feder  
**Metal&plastic rose** - springloaded

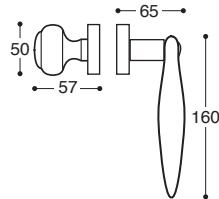

**K0051D**

PZ, Links / LH

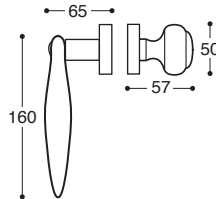

**K0051C**

PZ, Rechts / RH

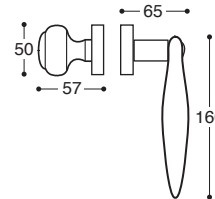

**K005SD**

PZ, Links / LH

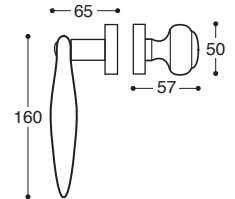

**K005SC**

PZ, Rechts / RH

**Fedra2005/T11**  
**Metall Rosetten** - Wechselgarnitur

**Fedra2005/52D**  
**Metall/Kunststoff Rosetten** - Wechselgarnitur

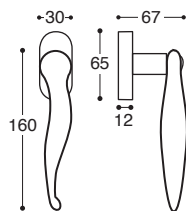

**K0056J**

Links / LH

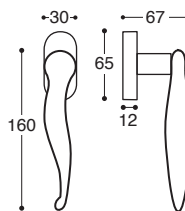

**K0056I**

Rechts / RH

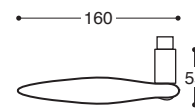

**K00509**

Links / LH

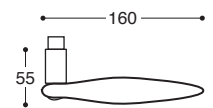

**K00508**

Rechts / RH

**Fedra2005 dk** Fenstergriffe  
Mit Rastung / Window handle - 8 pos. mech.

**Fedra2005**  
Drückerlochteil - Ohne Rosetten

\* auf Anfrage / on demand



matériau / material  
Aluminium tech  
Techno aluminium



**Fedra 2005.**  
design Enrico Baleri

finitions standards / standard finishes



**o6** - Chrome poli  
Polished chrome



**o8** - Chrome satiné  
Satin chrome



**SL** - Silver

finitions trendy / trendy finishes



**G3** - Gun metal



**15** - Noir mat\*  
Mat black\*



**16** - Blanc\*  
White\*



**K0056S**  
BDC / Latch

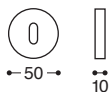

**K0056P**  
Cle L / Lock

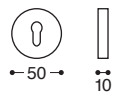

**K0056Y**  
Cle I / Cylinder

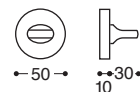

**K0056W**  
Cond/Dec C. 6/7/8 / Privacy

**Fedra2005/HB14** Métal et plastique rosace - avec ressort, carré 7 mm  
Metal&plastic rose - springloaded



**K0051S**  
BDC / Latch

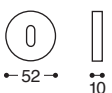

**K0051P**  
Cle L / Lock

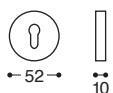

**K0051Y**  
Cle I / Cylinder

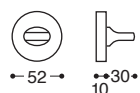

**K0051W**  
Cond/Dec C. 6/7/8 / Privacy

**Fedra2005/T11** Métal rosace - avec ressort, carré 7 mm / Metal rose - springloaded



**K005PS**  
BDC / Latch

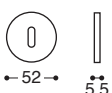

**K005PP**  
Cle L / Lock

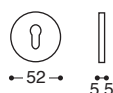

**K005PY**  
Cle I / Cylinder

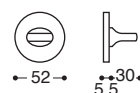

**K005PW**  
Cond/Dec C. 6/7/8 / Privacy

**Fedra2005/FLT** Rosette abaissée métal - avec ressort, carré 7 mm / Metal flat rose - springloaded

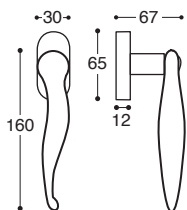

**K0056J**  
Gauche / LH

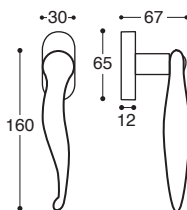

**K0056I**  
Droit / RH

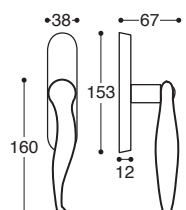

**K0056L**  
Gauche / LH

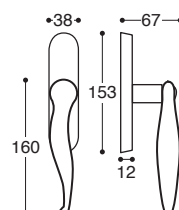

**K0056K**  
Droite / RH

**Fedra2005 DK** Poignée de fenêtre  
Mécan. 8 positions / Window handle - 8 pos. mech.

**Fedra2005 Martellina** Poignée de fenêtre  
Crémone / Window handle - Cremona

\* sur demande / on demand



Caffettiera napoletana 1981

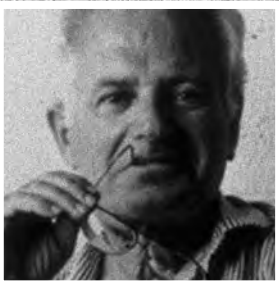

**RICCARDO DALISI**  
ARCHITETTO

Nato a Potenza, nel 1931, architetto e designer. Laureatosi in architettura presso il Politecnico di Napoli, abbandona, agli inizi degli anni settanta, l'insegnamento in facoltà e organizza, con gli studenti, azioni militanti e di carattere pedagogico nei quartieri poveri di Napoli. Lavora a contatto con il popolo, organizza performance e aiuta la creatività con materiali di recupero. Questa esperienza sfocia nel periodo dei Global Tools, cooperativa progettuale che lo vede protagonista. Disegna, tra le altre imprese, per Baleri, Glass, Oluce, Zabro (Zanotta). Nel 1981 conquista il compasso d'oro per la sua ricerca sulla caffettiera napoletana (per Alessi). Svolge attività critica e letteraria.

Born in Potenza in 1931, architect and designer. Graduated in architecture from Naples Polytechnic, in the early 1970s he abandoned

his teaching post there and organized, along with his students, militant pedagogical events in the poor neighborhoods of Naples. He worked in direct contact with the people, staging performances and promoting creativity with recycled materials. This experience led to the period of Global Tools, a design cooperative in which he was a key figure. Among his clients are Baleri, Glass, Oluce and Zabro (Zanotta). In 1981 he won the Golden Compass Award for his work on the Neapolitan coffeemaker (for Alessi). He is also active as a critic and writer.

Geboren in Potenza 1931, Architekt und Designer. Er absolvierte sein Architekturstudium an der technischen Hochschule in Neapel und verlies zu Beginn der siebziger Jahre seine akademische Lehrtätigkeit und organisierte mit den Studierenden pedagogische Tätigkeiten in den Armenviertel

von Neapel. Er arbeitet in Kontakt mit dem Volk, organisiert Performance und fördert die Kreativität mit Recyclingmaterial. Diese Tätigkeit führt zur Periode der Global Tools, ein kooperatives Projekt, bei dem er die Hauptfigur ist. Er zeichnet unter anderem für Baleri, Glass, Oluce, Zabro (Zanotta). 1981 gewinnt er den goldenen Kompass für seine Recherche über die neapolitanische Kaffeemaschine (für Alessi). Er ist als Kritiker und in der Fachliteratur tätig.

Né à Potenza en 1931, il est architecte et designer. Diplômé en architecture au Polytechnique de Naples, il abandonne au début des années soixante-dix, l'enseignement en faculté et organise avec les étudiants des actions militantes mais également pédagogiques dans les quartiers pauvres de Naples. Il travaille en contact avec le peuple, organise des performances et aide à la

créativité avec des matériaux recyclés. Cette expérience abouti à la période des Global Tools, une coopérative conceptuelle qui le voit protagoniste. Il conçoit, parmi les autres entreprises, pour Baleri, Glass, Oluce, Zabro (Zanotta). En 1981, il a remporté le prix Compasso d'oro pour sa recherche sur la cafetière napolitaine (pour Alessi). Il exerce une activité critique et littéraire.

KLEIS

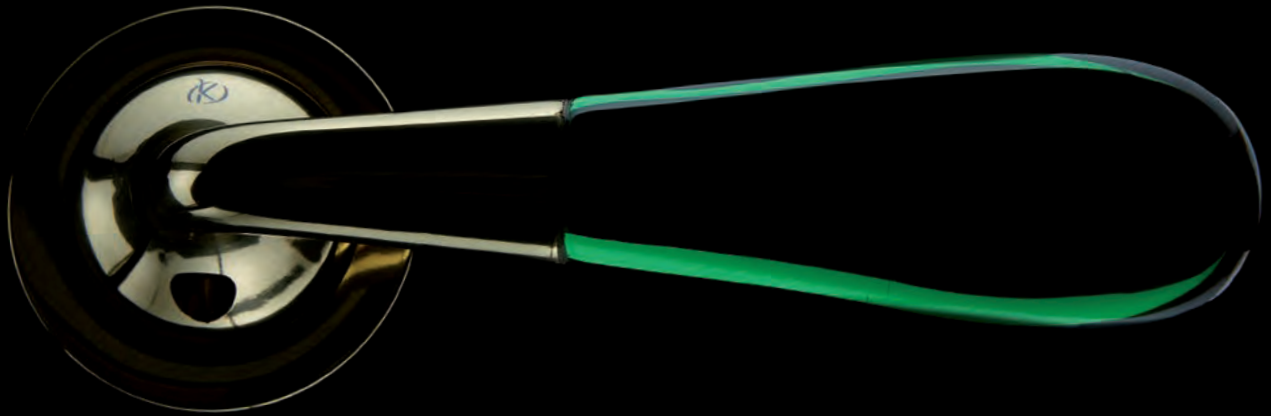

**Gemma.**

1991

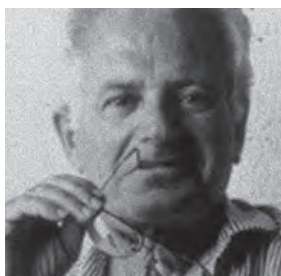

## Gemma.

design Riccardo Dalisi

materiale / material  
Ottone / Brass

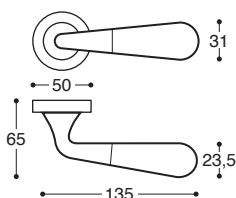

finiture standard / standard finishes



**XM** - Cromo sat. + vetro bianco acidato  
Satin chrome + sat. white glass



**XL** - Cromo sat. + vetro verde acidato  
Sat. chrome + sat. green glass



**XK** - Cromo sat. + vetro rosa acidato  
Satin chrome + satin pink glass

finiture standard / standard finishes



**XI** - Cromo sat. + vetro acquamarina acidato  
Sat. chrome + sat. light blue glass

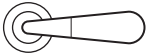
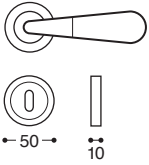
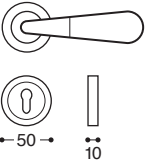
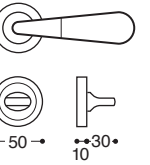

**XJ** - Cromo sat. + vetro blu acidato  
Satin chrome + sat. blue glass

 <p><b>K002A0</b> S/bocchetta / Latch</p>	 <p><b>K002A2</b> Patent / Lock</p>	 <p><b>K002A4</b> Yale / Cylinder</p>	 <p><b>K002A6</b> WC / Privacy - Q. 6/7/8</p>
--	--	--	--

**Gemma/HB6 Rosetta metallo - con molla / Metal rose - springloaded**

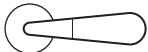
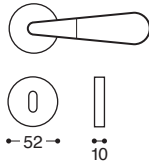
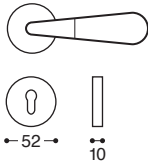
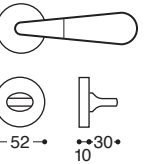
 <p><b>K00210</b> S/bocchetta / Latch</p>	 <p><b>K00212</b> Patent / Lock</p>	 <p><b>K00214</b> Yale / Cylinder</p>	 <p><b>K00216</b> WC / Privacy - Q. 6/7/8</p>
--	--	--	--

**Gemma/T11 Rosetta metallo - con molla / Metal rose - springloaded**

finiture standard / standard finishes



**XD** - Oro + vetro verde trasparente  
Pol. brass + transp. green glass



**XB** - Oro + vetro blu trasparente  
Pol. brass + transp. blue glass

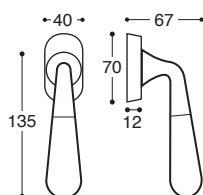

**K002AI**  
Senza mano / Without hand

**Gemma DK** - mov. 8 scatti  
Window handle - 8 pos. mech.

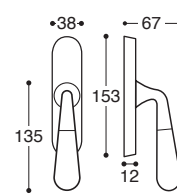

**K002AK**  
Senza mano / Without hand

**Gemma Martellina**  
Per finestra - Cremonese  
For window - Cremon

Material / material  
Messing / Brass

standard 

**Gemma.**  
design Riccardo Dalisi

Standardveredelungen / standard finishes



**XM** - Chrom matt  
+ matt Weißglas  
Satin chrome  
+ satin white glass



**XL** - Chrom matt  
+ matt Grün glas  
Satin chrome  
+ satin green glass



**XK** - Chrom matt  
+ matt Rosa glas  
Satin chrome  
+ satin pink glass



**XI** - Chrom matt  
+ matt Hellblau glas  
Satin chrome  
+ sat. light blue glass



**XJ** - Chrom matt  
+ matt Dunkelblau glas  
Satin chrome  
+ satin blue glass



**XD** - Messing poliert  
+ transparent Grün glas  
Polished brass  
+ transparent green glass



**XB** - Messing poliert  
+ transp. Dunkelblau glas  
Polished brass  
+ transparent blue glass

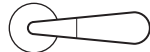

**K00210**

Ohne Schlüssel / Latch

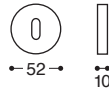
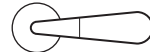

**K00213**

BB / Lock

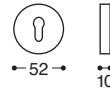
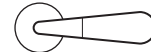

**K00215**

PZ / Cylinder

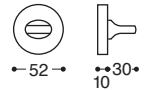
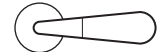

**K00217**

BAD S. 8 mm / Privacy

**Gemma/T11** Türgriff - Metall Rosetten DIN 38 mm - Mit Feder / **Metal rose** - springloaded

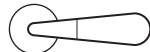

**K002S0**

Ohne Schlüssel / Latch

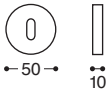
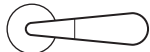

**K002S3**

BB / Lock

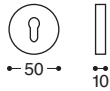
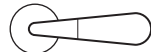

**K002S5**

PZ / Cylinder

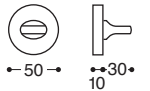
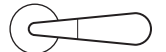

**K002S7**

BAD S. 8 mm / Privacy

**Gemma/52D** Türgriff - Metall/Kunststoff Rosetten DIN 38 mm - Mit Feder / **Metal rose** - springloaded

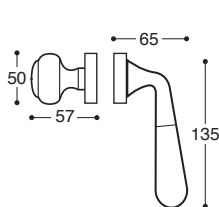

**K0021D**

PZ, Links / LH

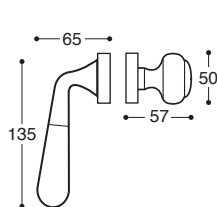

**K0021C**

PZ, Rechts / RH

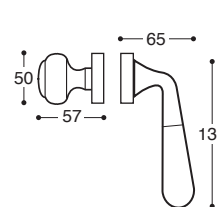

**K002SD**

PZ, Links / LH

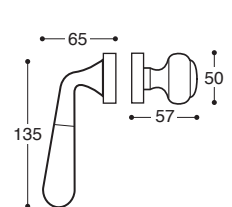

**K002SC**

PZ, Rechts / RH

**Gemma/T11**  
Metall Rosetten - Wechselgarnitur

**Gemma/52D**  
Metall/Kunststoff Rosetten - Wechselgarnitur

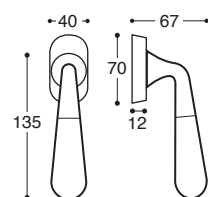

**K002AI**

Ohne Hand / Without hand

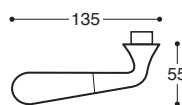

**K00209**

Links / LH

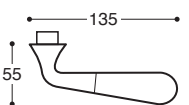

**K00208**

Rechts / RH

**Gemma DK** Fenstergriffe - Mit Rastung  
Window handle - 8 pos. mech.

**Gemma**  
Drückerlochteil - Ohne Rosetten

matériau / material  
Laiton / Brass

standard 

**Gemma.**  
design Riccardo Dalisi

finitions standards / standard finishes



**XM** - Chrome satiné  
+ verre blanc satiné  
Satin chrome  
+ satin white glass



**XL** - Chrome satiné  
+ verre vert satiné  
Satin chrome  
+ satin green glass



**XK** - Chrome satiné  
+ verre rose satiné  
Satin chrome  
+ satin pink glass



**XI** - Chrome satiné + verre  
aigue-marine satiné  
Satin chrome  
+ satin light blue glass



**XJ** - Chrome satiné  
+ verre bleu satiné  
Satin chrome  
+ satin blue glass



**XD** - Laiton poli  
+ verre vert transparent  
Polished brass  
+ transparent green glass



**XB** - Laiton poli  
+ verre bleu transparent  
Polished brass  
+ transparent blue glass



**K002AS**  
BDC / Latch

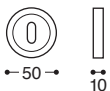

**K002AP**  
Cle L / Lock

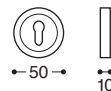

**K002AY**  
Cle I / Cylinder

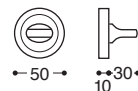

**K002AW**  
Cond/Dec C. 6/7/8 / Privacy

**Gemma/HB6 Métal rosace - avec ressort, carré 7 mm / Metal rose - springloaded**



**K0021S**  
BDC / Latch

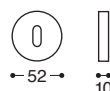

**K0021P**  
Cle L / Lock

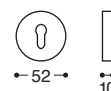

**K0021Y**  
Cle I / Cylinder



**K0021W**  
Cond/Dec C. 6/7/8 / Privacy

**Gemma/T11 Métal rosace - avec ressort, carré 7 mm / Metal rose - springloaded**

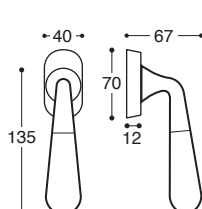

**K002AI**  
Sans main / Without hand

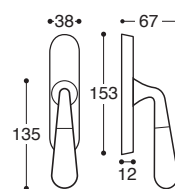

**K002AK**  
Sans main / Without hand

**Gemma DK** Poignée de fenetre  
Mécan. 8 positions / Window handle - 8 pos. mech.

**Gemma Martellina** Poignée de fenetre  
Crémone / Window handle - Cremon



monofuoco Origine 2008

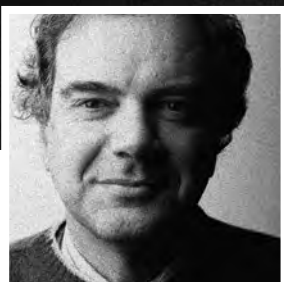

## MARCELLO CUTINO DESIGNER

Marcello Cutino si è formato presso l'Istituto d'Arte di Verona e il Politecnico di Design a Milano, dove si diploma in Industrial design. Insieme a Susanna Brugnoli, visual designer fonda nel 1980 lo studio BCF che affianca le aziende nei percorsi di innovazione e riposizionamento attraverso l'attività integrata dei tre settori che la compongono: design, comunicazione d'impresa, immagine. Negli oltre trent'anni di attività ha maturato un'importante expertise nei settori del bagno e della cucina affrontando diverse tipologie di prodotto per aziende a livello internazionale. È autore di numerosi articoli su riviste di design. Con lo Studio BCF ha ricevuto numerosi premi e riconoscimenti nazionali e internazionali.

Marcello Cutino graduated from the Istituto d'Arte di Verona and the Politecnico di Design in Milan where he

graduated in Industrial design. Together with Susanna Brugnoli, visual designer founded in 1980 the BCF study, which accompanies companies in innovation and repositioning through the integrated activities of the three sectors that make up it: design, business communication, image. In over thirty years of activity has gained an important expertise in the bathroom and kitchen sectors by addressing different types of products for companies at international level. He is the author of many articles on design magazines. With the Studio BCF has received numerous national and international awards and prizes.

Marcello Cutino hat seine Ausbildung am Kunstinstitut von Verona und dem Polytechnikum für Design in Mailand abgeschlossen. Gemeinsam mit Brugnoli, einer Visual Designerin, gründet er 1980 das Studio BCF und

begleitet mithilfe von drei Sektoren Unternehmen, die sich am Markt innovativ neu positionieren möchten: Design, Unternehmenskommunikation, Image. In den über 30 Jahren Firmenbestehen hat er wichtige Erfahrungen in den Bereichen Bad und Küche sammeln können, da er verschiedene Produkttypen für internationale Firmen entwickeln musste. Er ist Autor zahlreicher Artikel in Design-Zeitschriften. Mit dem Studio BCF hat er zahlreiche Preise und Auszeichnungen im In- und Ausland errungen.

Marcello Cutino s'est formé à l'Institut d'Art de Vérone et au Polytechnique de Design à Milan, dans lequel il a obtenu le diplôme de design industriel. Avec Susanna Brugnoli, visual designer il créait en 1980 le cabinet BCF qui accompagne les entreprises dans les parcours d'innovation et de repositionnement par l'intermédiaire de l'activité

intégrée des trois secteurs qui la composent : design, communication d'entreprise, image. Au cours des plus de trente ans d'activité il a obtenu une importante expertise dans les secteurs de la salle de bain et de la cuisine en abordant différents types de produits pour les entreprises au niveau international. Il est l'auteur de nombreux articles sur des revues de design. Avec le studio BCF il a obtenu de nombreux prix et reconnaissances nationales et internationales



KLEIS



**Grafite.**

2007

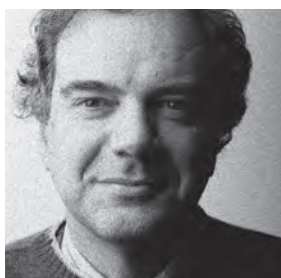

**Grafite.**  
design Marcello Cutino BCF

materiale / material  
**Alluminio tecnologico**  
Techno aluminum

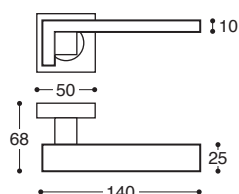

finiture standard / standard finishes



**GC** - Grafite + cromo  
Graphite + polished chrome







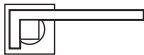
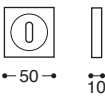
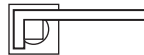
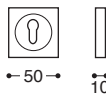
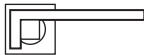
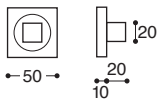

**69** - Nikmat + cromo  
Nikmat + polished chrome

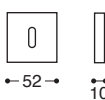

**PC** - Perla + cromo  
Silver + polished chrome

 <p><b>K00M50</b> S/bocchetta / Latch</p>	  <p><b>K00M52</b> Patent / Lock</p>	  <p><b>K00M54</b> Yale / Cylinder</p>	  <p><b>K00M56</b> WC / Privacy - Q. 6/7/8</p>
--	--	--	--

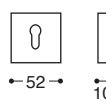
**Grafite/Quad Rosetta metallo - con molla / Metal rose - springloaded**

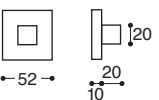
 <p><b>K00MV0</b> S/bocchetta / Latch</p>	  <p><b>K00MV2</b> Patent / Lock</p>	  <p><b>K00MV4</b> Yale / Cylinder</p>	  <p><b>K00MV6</b> WC / Privacy - Q. 6/7/8</p>
--	--	--	--

**Grafite/Q11 Rosetta metallo - con molla / Metal rose - springloaded**

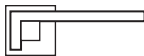
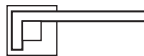
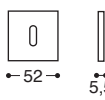
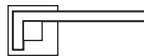
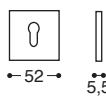
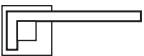
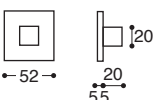
 <p><b>K00MF0</b> S/bocchetta / Latch</p>	  <p><b>K00MF2</b> Patent / Lock</p>	  <p><b>K00MF4</b> Yale / Cylinder</p>	  <p><b>K00MF6</b> WC / Privacy - Q. 6/7/8</p>
--	--	--	--

**Grafite/FLQ Rosetta ribassata metallo - con molla / Metal flat rose - springloaded**

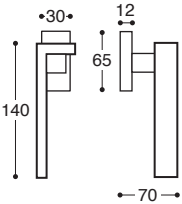
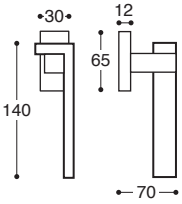
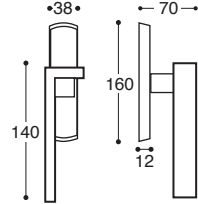
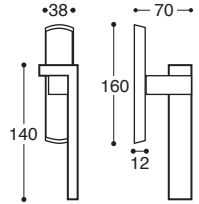
 <p><b>K00M5J</b> SX - LH</p>	 <p><b>K00M5I</b> DX - RH</p>	 <p><b>K00M5L</b> SX / LH</p>	 <p><b>K00M5K</b> DX / RH</p>
--	--	--	--

**Grafite DK - mov. 8 scatti**  
Window handle - 8 pos. mech.

**Grafite Martellina**  
Per finestra - Cremonese / For window - Cremon

Material / material  
Tech-Aluminium  
Techno aluminium



**Grafite.**  
design Marcello Cutino BCF

Standardveredelungen / standard finishes



**GC** - Graphit + Chrom  
Graphite + polish. chrome



**69** - Nickel matt + Chrom  
Nikmat + polished chrome



**PC** - Silber + Chrom  
Silver + polished chrome

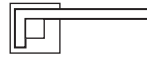

**K00MV0**

Ohne Schlüssel / Latch

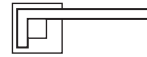

**K00MV3**

BB / Lock

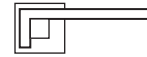

**K00MV5**

PZ / Cylinder

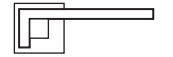

**K00MV7**

BAD S. 6/7/8 / Privacy

**Grafite/Q11** Türgriff - Metall Rosetten DIN 38 mm - Mit Feder / **Metal rose** - springloaded



**K00MB0**

Ohne Schlüssel / Latch



**K00MB3**

BB / Lock

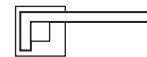

**K00MB5**

PZ / Cylinder

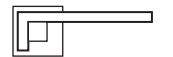

**K00MB7**

BAD S. 6/7/8 / Privacy

**Grafite/50x50** Türgriff - Metall/Kunststoff Rosetten DIN 38 mm - Mit Feder  
**Metal&plastic rose** - springloaded

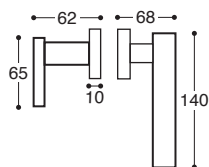

**K00MVD**

PZ, Links / LH

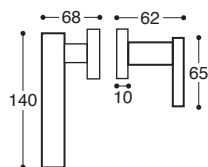

**K00MVC**

PZ, Rechts / RH

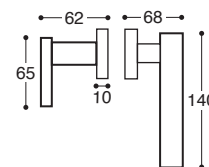

**K00MBD**

PZ, Links / LH

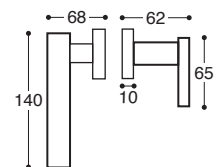

**K00MBC**

PZ, Rechts / RH

**Grafite/Q11**  
**Metall Rosetten** - Wechselgarnitur

**Grafite/50x50**  
**Metall/Kunststoff Rosetten** - Wechselgarnitur

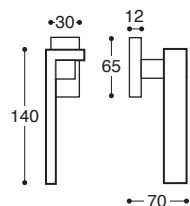

**K00M5J**

Links / LH

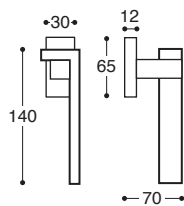

**K00M5I**

Rechts / RH

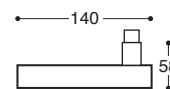

**K00M09**

Links / LH



**K00M08**

Rechts / RH

**Grafite DK** Fenstergriffe - Mit Rastung  
Window handle - 8 pos. mech.

**Grafite**  
Drückerlochteil - Ohne Rosetten

matériau / material  
Aluminium tech  
Techno aluminium

standard 

**Grafite.**  
design Marcello Cutino BCF

finitions standards / standard finishes



**GC** - Graphite + chrome poli  
Graphite + pol. chrome



**69** - Nickel satiné + chrome poli  
Nikmat + pol. chrome



**PC** - Silver + chrome poli  
Silver + polished chrome

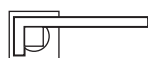

**K00M5S**  
BDC / Latch

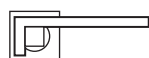

**K00M5P**  
Cle L / Lock

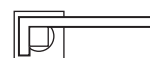

**K00M5Y**  
Cle I / Cylinder



**K00M5W**  
Cond/Dec C. 6/7/8 / Privacy

**Grafite/Quad Métal rosace** - avec ressort, carré 7 mm / **Metal rose** - springloaded



**K00MVS**  
BDC / Latch



**K00MVP**  
Cle L / Lock



**K00MZY**  
Cle I / Cylinder



**K00MVW**  
Cond/Dec C. 6/7/8 / Privacy

**Grafite/Q11 Métal rosace** - avec ressort, carré 7 mm / **Metal rose** - springloaded



**K00MFS**  
BDC / Latch



**K00MFP**  
Cle L / Lock



**K00MFY**  
Cle I / Cylinder



**K00MFW**  
Cond/Dec C. 6/7/8 / Privacy

**Grafite/FLQ Rosette abaissée métal** - avec ressort, carré 7 mm / **Metal flat rose** - springloaded

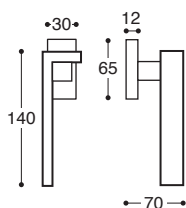

**K00M5J**  
Gauche - LH

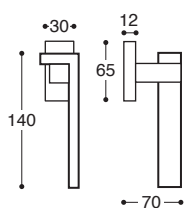

**K00M5I**  
Droite - RH

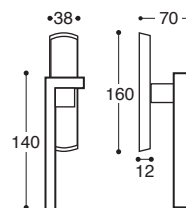

**K00M5L**  
Gauche - LH

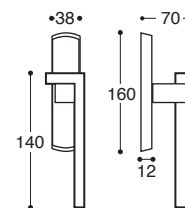

**K00M5K**  
Droite - RH

**Grafite DK** Poignée de fenêtre  
Mécan. 8 positions / Window handle - 8 pos. mech.

**Grafite Martellina** Poignée de fenêtre  
Crémone / Window handle - Cremon



Libra 2010



**FABRIZIO CESTER**  
DESIGNER

Nato a Venezia nel 1960, è libero professionista dal 1995. Inizialmente, si dedica ad opere di restauro conservativo di incarico pubblico. Nel corso degli anni novanta, il suo interesse personale si indirizza verso temi dell'architettura degli interni, del disegno industriale, dello yacht design, degli allestimenti fieristici e del mobile classico, ottenendo riconoscimenti internazionali. In qualità di designer collabora con qualificate industrie per le quali ha progettato oggetti ed articoli tecnici d'arredo. Partecipa a mostre e concorsi di architettura e design; i suoi progetti sono menzionati su diverse pubblicazioni. Vive e lavora a Venezia.

Born in Venice in 1960, since 1995 works freelance. Initially, he devoted himself to public restoration works. During the nineties, he gained international recognition when his personal interest turned towards motives of interior architecture, industrial design,

yacht design stand dressing and classical furniture. As a designer he works with qualified industries, for which he designs objects and articles of technical furniture. He participated in exhibitions and contests of architecture and design; his projects are mentioned in several publications. He lives and works at Venice.

1960 in Venedig geboren ist er ab 1995 freiberuflich tätig. Zu Beginn widmet er sich der Restaurierung von Werken auf öffentlichen Auftrag. Im Lauf der neunziger Jahre fokussiert er sich auf Themen der Innenraumarchitektur, des technischen Zeichnens, des Yacht Design, der Ausstattungen von Messen und der klassischen Möbel und erhält internationale Auszeichnungen. Al Designer arbeitet er mit qualifizierten Unternehmen zusammen für die er Ausstattungs- und technische Gegenstände gestaltet. Er nimmt an

Ausstellungen und Architektur- und Designwettbewerbe teil; seine Projekte werden in zahlreichen Publikationen erwähnt. Er lebt und arbeitet in Venedig.

Né à Venise en 1960, il travaille comme indépendant depuis 1995. Au début, il se consacre à des travaux de restauration et conservation de la fonction publique. Au cours des années quatre-vingt-dix, son intérêt personnel s'oriente vers les thèmes de l'architecture d'intérieur, de dessin industriel, de la conception du yacht, des stands de foires et du mobilier classique, obtenant des reconnaissances internationales. En qualité de designer, il collabore avec des industries qualifiées pour lesquelles il a conçu des objets et articles techniques de mobilier. Il participe aux expositions et concours d'architecture et de design; ses projets sont mentionnés dans plusieurs publications. Il vit et travaille à Venise.

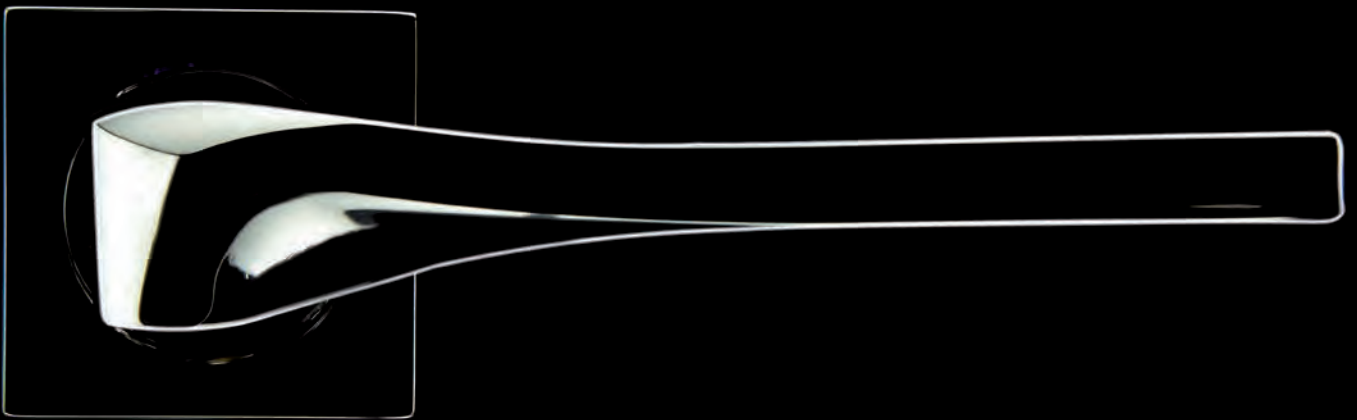

**La.**

2005



**La.**  
design Fabrizio Cester

materiale / material  
**Ottone / Brass**

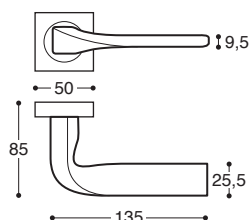

finiture standard / standard finishes

finiture trendy / trendy finishes



**06** - Cromo lucido  
Polished chrome



**33** - Nickel satin. verniciato  
Satin nickel



**G3** - Gun metal



**08** - Cromo satinato  
Satin chrome



**15** - Nero opaco\*  
Mat black\*



**22** - Nickel lucido  
Polished nickel



**16** - Bianco\*  
White\*

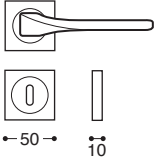
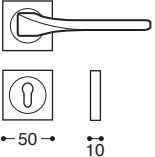
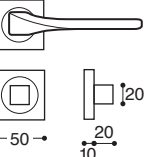

 <p><b>K00H50</b> S/bocchetta / Latch</p>	 <p><b>K00H52</b> Patent / Lock</p>	 <p><b>K00H54</b> Yale / Cylinder</p>	 <p><b>K00H56</b> WC / Privacy - Q. 6/7/8</p>
--	--	--	--

**La/Quad Rosetta metallo - con molla / Metal rose - springloaded**

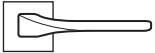
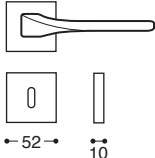
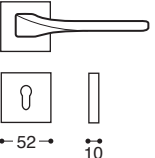
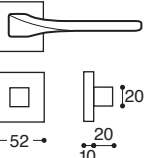
 <p><b>K00HV0</b> S/bocchetta / Latch</p>	 <p><b>K00HV2</b> Patent / Lock</p>	 <p><b>K00HV4</b> Yale / Cylinder</p>	 <p><b>K00HV6</b> WC / Privacy - Q. 6/7/8</p>
--	--	--	--

**La/Q11 Rosetta metallo - con molla / Metal rose - springloaded**

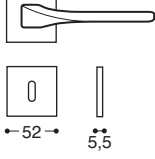
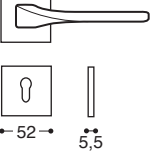
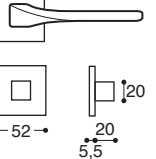
 <p><b>K00HF0</b> S/bocchetta / Latch</p>	 <p><b>K00HF2</b> Patent / Lock</p>	 <p><b>K00HF4</b> Yale / Cylinder</p>	 <p><b>K00HF6</b> WC / Privacy - Q. 6/7/8</p>
--	--	--	--

**La/FLQ Rosetta ribassata metallo - con molla / Metal flat rose - springloaded**

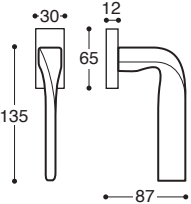
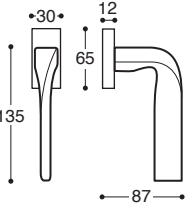
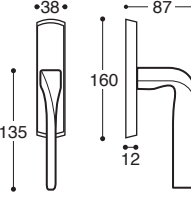
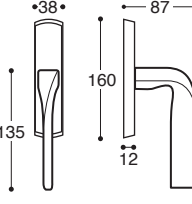
 <p><b>K00H5J</b> SX - LH</p>	 <p><b>K00H5I</b> DX - RH</p>	 <p><b>K00H5L</b> SX / LH</p>	 <p><b>K00H5K</b> DX / RH</p>
--	--	--	--

**La DK - mov. 8 scatti**  
Window handle - 8 pos. mech.

**La Martellina**  
Per finestra - Cremonese / For window - Cremon

\* a richiesta / on demand

Material / material  
Messing / Brass

standard 

**La.**  
design Fabrizio Cester

Standardveredelungen / standard finishes



**o6** - Chrom  
Polished chrome



**o8** - Chrom matt  
Satin Chrome



**22** - Nickel  
Polished nickel



**33** - Nickel matt  
Satin nickel

Trendy Veredelungen / trendy finishes



**G3** - Gun metal



**15** - Matt schwarz\*  
Mat black\*



**16** - Weiß\*  
White\*

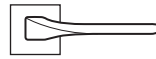

**K00HV0**  
Ohne Schlüssel / Latch

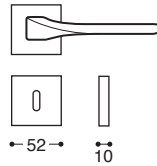

**K00HV3**  
BB / Lock

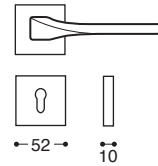

**K00HV5**  
PZ / Cylinder

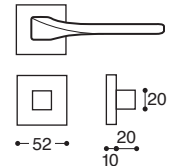

**K00HV7**  
BAD S. 6/7/8 / Privacy

**La/Q11** Türgriff - Metall Rosetten DIN 38 mm - Mit Feder / **Metal rose** - springloaded



**K00HB0**  
Ohne Schlüssel / Latch

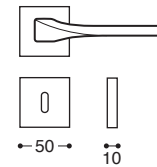

**K00HB3**  
BB / Lock

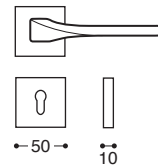

**K00HB5**  
PZ / Cylinder

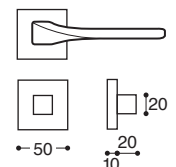

**K00HB7**  
BAD S. 6/7/8 / Privacy

**La/50x50** Türgriff - Metall/Kunststoff Rosetten DIN 38 mm - Mit Feder  
**Metal&plastic rose** - springloaded

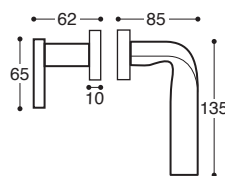

**K00HVD**  
PZ, Links / LH

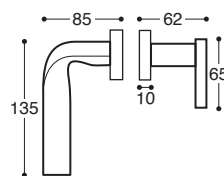

**K00HVC**  
PZ, Rechts / RH

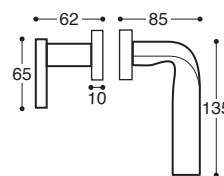

**K00HBD**  
PZ, Links / LH

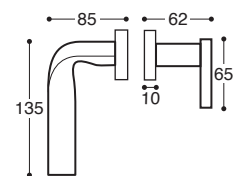

**K00HBC**  
PZ, Rechts / RH

**La/Q11**  
Metall Rosetten - Wechselgarnitur

**La/50x50**  
Metall/Kunststoff Rosetten - Wechselgarnitur

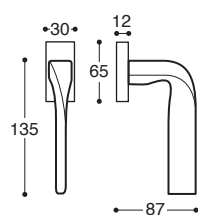

**K00H5J**  
Links / LH

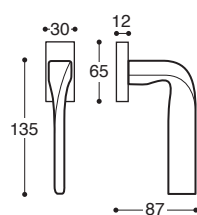

**K00H5I**  
Rechts / RH

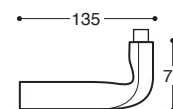

**K00H09**  
Links / LH

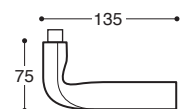

**K00H08**  
Rechts / RH

**La DK** Fenstergriffe - Mit Rastung  
Window handle - 8 pos. mech.

**La**  
Drückerlochteil - Ohne Rosetten

\* auf Anfrage / on demand

matériau / material  
Laiton / Brass

standard 

**La.**  
design Fabrizio Cester

finitions standards / standard finishes



**o6** - Chrome poli  
Polished chrome



**o8** - Chrome satiné  
Satin Chrome



**22** - Nickel poli  
Polished nickel



**33** - Nickel satiné  
Satin nickel

finitions trendy / trendy finishes



**G3** - Gun metal



**15** - Noir mat\*  
Mat black\*



**16** - Blanc\*  
White\*



**K00H5S**  
BDC / Latch



**K00H5P**  
Cle L / Lock



**K00H5Y**  
Cle I / Cylinder



**K00H5W**  
Cond/Dec C. 6/7/8 / Privacy

**La/Quad Métal rosace** - avec ressort, carré 7 mm / **Metal rose** - springloaded



**K00HVS**  
BDC / Latch



**K00HVP**  
Cle L / Lock



**K00HVV**  
Cle I / Cylinder



**K00HVVW**  
Cond/Dec C. 6/7/8 / Privacy

**La/Q11 Métal rosace** - avec ressort, carré 7 mm / **Metal rose** - springloaded



**K00HFS**  
BDC / Latch



**K00HFP**  
Cle L / Lock



**K00HFY**  
Cle I / Cylinder



**K00HFW**  
Cond/Dec C. 6/7/8 / Privacy

**La/FLQ Rosette abaissée métal** - avec ressort, carré 7 mm / **Metal flat rose** - springloaded

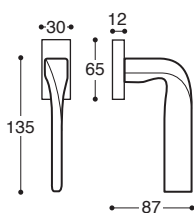

**K00H5J**  
Gauche - LH

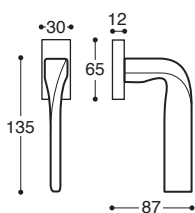

**K00H5I**  
Droit - RH

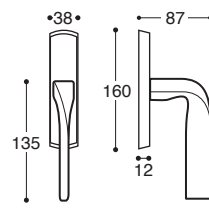

**K00H5L**  
Gauche / LH

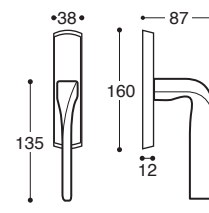

**K00H5K**  
Droit / RH

**La DK Poignée de fenêtre**  
Mécan. 8 positions / Window handle - 8 pos. mech.

**La Martellina Poignée de fenêtre**  
Crémone / Window handle - Cremon

\* sur demande / on demand



Stazione Toledo della metropolitana di Napoli, 2012



**OSCAR TUSQUETS  
BLANCA**  
ARCHITETTO

Architetto per formazione, pittore per inclinazione e disegnatore per vocazione, Tusquets è il prototipo dell'artista integrale. I suoi lavori fanno parte delle collezioni dei Musei più importanti del mondo. Ha ricevuto numerosi premi e riconoscimenti sia per le opere architettoniche che per oggetti d'uso quotidiano: la Medaglia d'Oro al merito dalle Belle Arti Spagnole e l'onorificenza di Cavaliere dell'Ordine delle Arti e delle Lettere di Francia. Nel 1994 ha pubblicato il suo primo libro come saggista, al quale si è recentemente aggiunto un secondo, entrambi realizzati in varie edizioni.

Architect by training, painter by inclination, and draftsman by vocation, Tusquets is the prototype of the complete artist. His works have been acquired by the most important museums in the world. He has received numerous prizes and honors

for both his architectural works and product designs, including: the Gold Medal in Fine Arts from his native Spain, as well as having been made a Chevalier of the French Order of Arts and Letters. In 1994 he published his first book as an essayist, to which he has recently added a second volume, both of which are enjoying continuous reeditions.

Von der Ausbildung her Architekt, mit einem Hang zur Malerei und als Berufung Zeichner ist Tusquets der Prototyp des vollständigen Künstlers. Seine Werke gehören zu den Sammlungen der wichtigsten Museen der Welt. Er erhielt zahlreiche Preise und Auszeichnungen sowohl für architektonische Werke als auch für Gegenstände des täglichen Bedarfs: die Goldmedaille der spanischen schönen Künste und die Auszeichnung als Ritter des Orden der Künste und der Literatur von Frankreich. 1994 hat er sein erstes Buch

veröffentlicht, zu dem ein zweites dazukommt, beide in verschiedenen Ausgaben erschienen. Architecte de formation, peintre par inclination et dessinateur par vocation, Tusquets est le prototype d'artiste intégral. Ses travaux font partie des collections des Musées les plus importants du monde. Il a reçu de nombreux prix et reconnaissances aussi bien pour ses œuvres architecturales que pour les objets d'usage quotidien: la Médaille d'Or au mérite décernée l'École des Beaux-arts Espagnoles et le titre de Chevalier de l'Ordre des Arts et des Lettres de France. En 1994, il a publié son premier livre en tant que essayiste, auquel s'est récemment joint un second, tous les deux réalisés en plusieurs éditions.

KLEIS

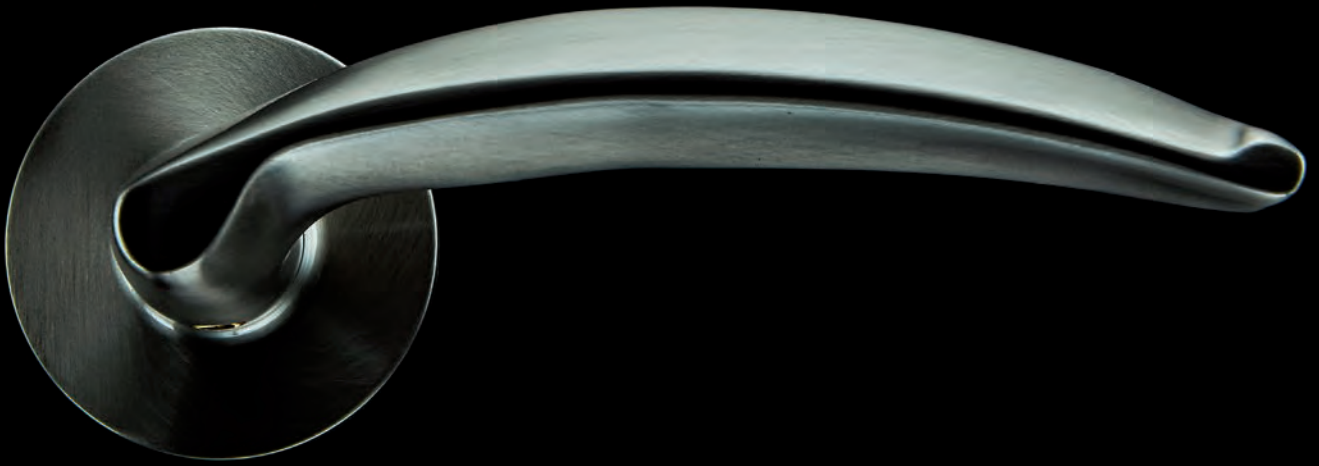

**Manos.**

1995



## Manos.

design Oscar Tusquets Blanca

finiture standard / standard finishes

materiale / material  
**Ottone / Brass**



**02 - Ottone satinato**  
Satin brass



**33 - Nickel satinato verniciato**  
Satin nickel

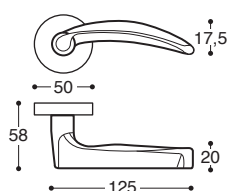

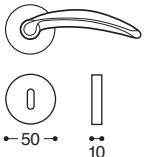
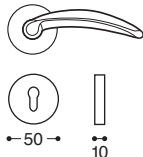
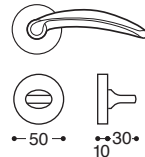
 <p><b>K00860</b> S/bocchetta / Latch</p>	 <p><b>K00862</b> Patent / Lock</p>	 <p><b>K00864</b> Yale / Cylinder</p>	 <p><b>K00866</b> WC / Privacy - Q. 6/7/8</p>
--	--	--	--

**Manos/HB14** Rosetta metallo&plastica - con molla / **Metal&plastic rose** - springloaded

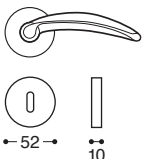
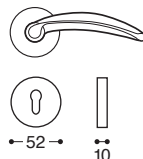
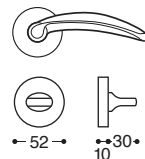
 <p><b>K00810</b> S/bocchetta / Latch</p>	 <p><b>K00812</b> Patent / Lock</p>	 <p><b>K00814</b> Yale / Cylinder</p>	 <p><b>K00816</b> WC / Privacy - Q. 6/7/8</p>
--	--	--	--

**Manos/T11** Rosetta metallo - con molla / **Metal rose** - springloaded

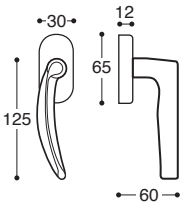
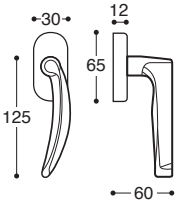
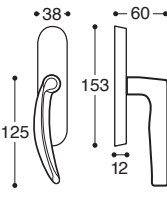
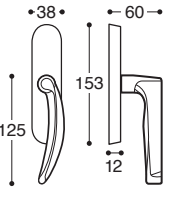
 <p><b>K0086J</b> SX - LH</p>	 <p><b>K0086I</b> DX - RH</p>	 <p><b>K0086L</b> SX / LH</p>	 <p><b>K0086K</b> DX / RH</p>
--	--	--	--

**Manos DK** - mov. 8 scatti  
Window handle - 8 pos. mech.

**Manos Martellina**  
Per finestra - Cremonese / For window - Cremon

Material / material  
Messing / Brass



**Manos.**  
design Oscar Tusquets Blanca

Standardveredelungen / standard finishes



**02** - Messing matt  
Satin brass



**33** - Nickel matt  
Satin nickel



**K00810**

Ohne Schlüssel / Latch



**K00813**

BB / Lock

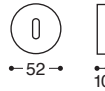

**K00815**

PZ / Cylinder



**K00817**

BAD S. 6/7/8 / Privacy

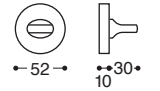

**Manos/T11 Türgriff** - Metall Rosetten DIN 38 mm - Mit Feder / **Metal rose** - springloaded



**K008S0**

Ohne Schlüssel / Latch



**K008S3**

BB / Lock

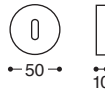

**K008S5**

PZ / Cylinder

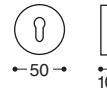

**K008S7**

BAD S. 6/7/8 / Privacy

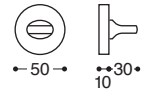

**Manos/52D Türgriff** - Metall/Kunststoff Rosetten DIN 38 mm - Mit Feder  
**Metal&plastic rose** - springloaded

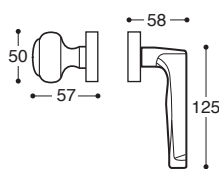

**K0081D**

PZ, Links / LH

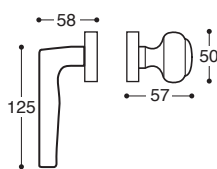

**K0081C**

PZ, Rechts / RH

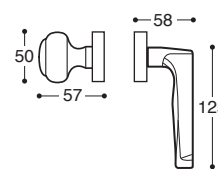

**K008SD**

PZ, Links / LH

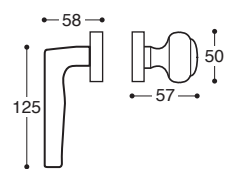

**K008SC**

PZ, Rechts / RH

**Manos/T11**  
**Metall Rosetten** - Wechselgarnitur

**Manos/52D**  
**Metall/Kunststoff Rosetten** - Wechselgarnitur

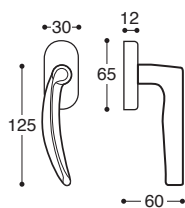

**K0086J**

Links / LH

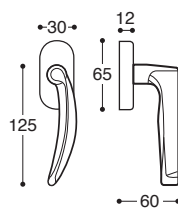

**K0086I**

Rechts / RH

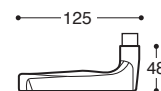

**K00809**

Links / LH

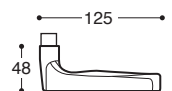

**K00808**

Rechts / RH

**Manos DK Fenstergriffe** - Mit Rastung  
Window handle - 8 pos. mech.

**Manos**  
Drückerlochteil - Ohne Rosetten



matériau / material  
Laiton / Brass

standard 

**Manos.**  
design Oscar Tusquets Blanca

finitions standards / standard finishes



**02** - Laiton satiné  
Satin brass



**33** - Nickel satiné  
Satin nickel



**K0086S**  
BDC / Latch

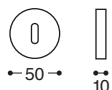

**K0086P**  
Cle L / Lock

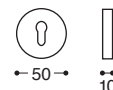

**K0086Y**  
Cle I / Cylinder



**K0086W**  
Cond/Dec C. 6/7/8 / Privacy

**Manos/HB14 Métal et plastique rosace** - avec ressort, carré 7 mm  
**Metal&plastic rose** - springloaded



**K0081S**  
BDC / Latch

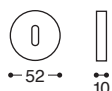

**K0081P**  
Cle L / Lock

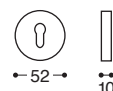

**K0081Y**  
Cle I / Cylinder

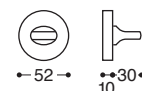

**K0081W**  
Cond/Dec C. 6/7/8 / Privacy

**Manos/T11 Métal rosace** - avec ressort, carré 7 mm / **Metal rose** - springloaded

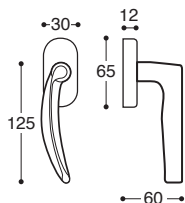

**K0086J**  
Gauche - LH

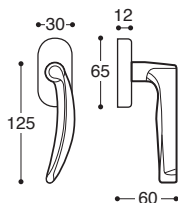

**K0086I**  
Droit - RH

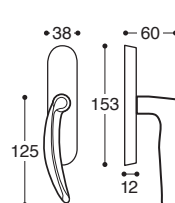

**K0086L**  
Gauche - LH

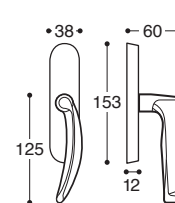

**K0086K**  
Droit - RH

**Manos DK** Poignée de fenetre  
Mécan. 8 positions / Window handle - 8 pos. mech.

**Manos Martellina** Poignée de fenetre  
Crémone / Window handle - Cremon

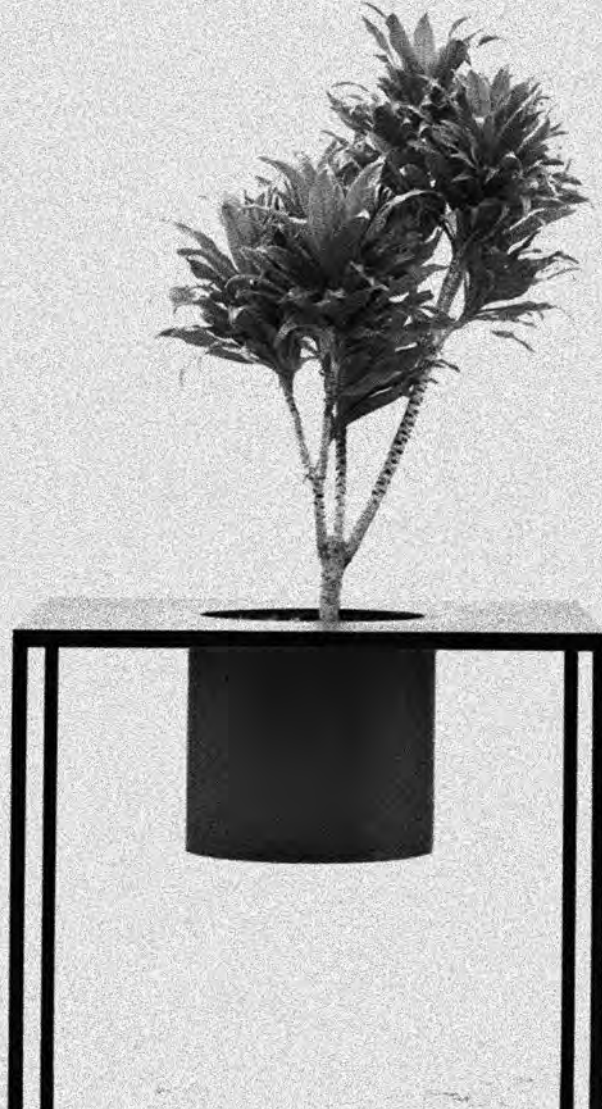

Collezione Riviera 2009

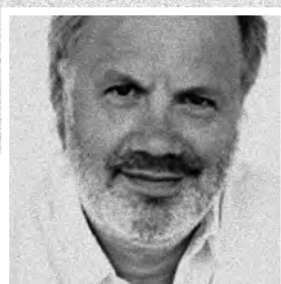

**ALDO CIBIC**  
ARCHITETTO

Architetto e designer nato a Vicenza nel 1956, conosce Ettore Sottsass nel 1979 e nel 1980, con Marco Zanini e Matteo Thun fonda Sottsass Associati. Partecipa attivamente a Memphis di cui è fondatore con Sottsass e Michele De Lucchi. Nel 1989 fonda con Antonella Spiezio, la Cibic & Partners, lo studio in cui oltre all'attività personale di designer, per iniziative proprie e per diverse aziende, sviluppa un'attività nel campo dei progetti di interni e di architettura in Italia e all'estero. Dal 1989 è docente presso la Domus Accademy e dal 1997 docenze presso il Corso di Laurea in Disegno Industriale del Politecnico di Milano, presso il Royal College of Art di Londra, e presso il Corso di Laurea in Disegno Industriale dello IUAV. Nel 2005 diventa Direttore del Dipartimento di Design di Fabbrica, Centro di Ricerca sulla Comunicazione di Benetton.

Architect and designer born in Vicenza in 1956, he knows Ettore Sottsass in 1979 and 1980, with Marco Zanini and Matteo Thun founded Sottsass Associati. He actively participates in Memphis, whose founder is Sottsass and Michele De Lucchi. In 1989 he founded with Antonella Spiezio, Cella & Partners, the studio, in which, besides the personal work of designers, for their own initiatives and for different companies, develops an activity in the field of interior and architectural projects in Italy and abroad. Since 1989 he has been a lecturer at the Domus Accademy and since 1997 he has been teaching at the Milan Polytechnic Degree Course in Industrial Design at the Royal College of Art in London and at the IUAV Degree Course in Industrial Design. In 2005 he became Director of the Department of Design of Fabbrica, Benetton Communication Research Center.

Architekt und Designer, 1956 in Vicenza geboren, 1979 lernt er Ettore Sottsass kennen und gründet 1980 mit Marco Zanini und Matteo Thun das Unternehmen Sottsass Associati. Er arbeitet aktiv an Memphis mit, das er gemeinsam mit Sottsass und Michele De Lucchi gründet. 1989 gründet er mit Antonella Spiezio Cibic & Partners, das Studio, in dem er, neben seiner persönlichen Aktivität als Designer, auf eigene Initiative und für verschiedene Unternehmen auch im Bereich der Innen- und Außenarchitektur in Italien und im Ausland tätig ist. Seit 1989 ist er Dozent an der Domus Accademy und seit 1997 lehrt er auch im Studiengang für Industriedesign am Polytechnikum in Mailand, am Royal College of Art in London und dem Studiengang für Industriedesign der IUAV. 2005 wird er Abteilungsleiter für Fabrikdesign und das Forschungszentrum für Kommunikation bei Benetton.

Architecte et designer né à Vicence en 1956, il fait la connaissance d'Ettore Sottsass en 1979 et en 1980, avec Marc Zanini et Matteo Thun il crée Sottsass Associati. Il participe activement à Memphis dont il est fondateur avec Sottsass et Michele De Lucchi. En 1989 il crée avec Antonella Spiezio, le Cibic & Partners, le cabinet dans lequel en plus de l'activité personnelle de designer, de sa propre initiative et pour différentes entreprises, il développe une activité dans le domaine des projets d'intérieurs et d'architecture en Italie et à l'étranger. A partir de 1989 il enseigne à la Domus Accademy et à partir de 1997 dans le cursus de dessin industriel du Polytechnique de Milan, au Royal College of Art de Londres, et dans le cursus de dessin industriel de l'IUAV. En 2005 il devient Directeur du Département de Design de Fabbrica, Centre de Recherche sur la Communication de Benetton.

KLEIS



**Minerva.**

2000



**Minerva.**  
design Aldo Cibic

materiale / material  
**Ottone / Brass**

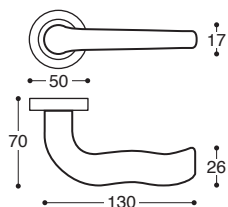

finiture standard / standard finishes



**00** - Oro  
Polished brass



**08** - Cromo satinato  
Satin chrome

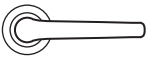
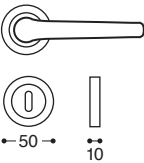
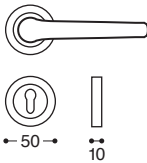
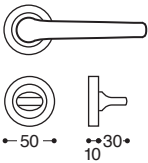

**33** - Nickel satinato verniciato  
Satin nickel

 <p><b>K00DA0</b> S/bocchetta / Latch</p>	 <p><b>K00DA2</b> Patent / Lock</p>	 <p><b>K00DA4</b> Yale / Cylinder</p>	 <p><b>K00DA6</b> WC / Privacy - Q. 6/7/8</p>
--	--	--	--

**Minerva/HB6 Rosetta metallo - con molla / Metal rose - springloaded**

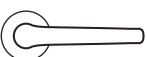
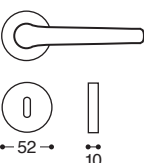
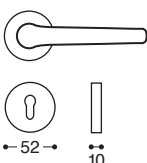
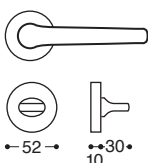
 <p><b>K00D10</b> S/bocchetta / Latch</p>	 <p><b>K00D12</b> Patent / Lock</p>	 <p><b>K00D14</b> Yale / Cylinder</p>	 <p><b>K00D16</b> WC / Privacy - Q. 6/7/8</p>
--	--	--	--

**Minerva/T11 Rosetta metallo - con molla / Metal rose - springloaded**

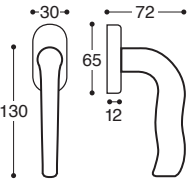
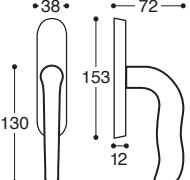
 <p><b>K00DAI</b> Senza mano / Without hand</p>	 <p><b>K00DAK</b> Senza mano / Without hand</p>
--	--

**Minerva DK - mov. 8 scatti**  
Window handle - 8 pos. mech.

**Minerva Martellina**  
Per finestra - Cremonese / For window - Cremon

Material / material  
Messing / Brass



**Minerva.**  
design Aldo Cibic

Standardveredelungen / standard finishes



**00** - Messing poliert  
Polished brass



**08** - Chrom matt  
Satin chrome



**33** - Nickel matt  
Satin nickel

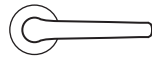

**K00D10**

Ohne Schlüssel / Latch

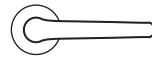

**K00D13**

BB / Lock

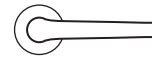

**K00D15**

PZ / Cylinder

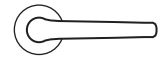

**K00D17**

BAD S. 6/7/8 / Privacy

**Minerva/T11 Türgriff** - Metall Rosetten DIN 38 mm - Mit Feder / **Metal rose** - springloaded

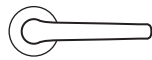

**K00DS0**

Ohne Schlüssel / Latch

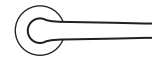

**K00DS3**

BB / Lock

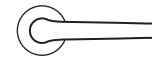

**K00DS5**

PZ / Cylinder

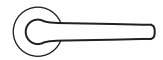

**K00DS7**

BAD S. 6/7/8 / Privacy

**Minerva/52D Türgriff** - Metall/Kunststoff Rosetten DIN 38 mm - Mit Feder  
**Metal&plastic rose** - springloaded

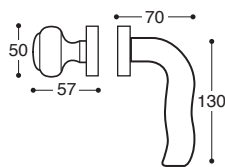

**K00D1D**

PZ, Links / LH

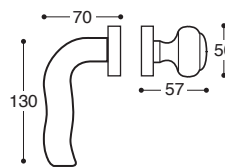

**K00D1C**

PZ, Rechts / RH

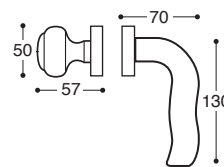

**K00DSD**

PZ, Links / LH

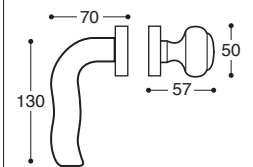

**K00DSC**

PZ, Rechts / RH

**Minerva/T11**  
**Metall/Kunststoff Rosetten** - Wechselgarnitur

**Minerva/52D**  
**Metall/Kunststoff Rosetten** - Wechselgarnitur

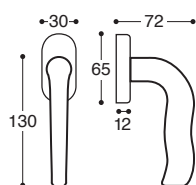

**K00DAI**

Ohne Hand / Without hand

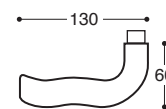

**K00D08**

Rechts / RH

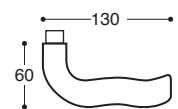

**K00D09**

Links / LH

**Minerva DK Fenstergriffe** - Mit Rastung  
Window handle - 8 pos. mech.

**Minerva**  
Drückerlochteil - Ohne Rosetten

matériau / material  
Laiton / Brass

standard 

**Minerva.**  
design Aldo Cibic

finitions standards / standard finishes



**00** - Laiton poli  
Polished brass



**08** - Chrome satiné  
Satin chrome



**33** - Nickel satiné  
Satin nickel

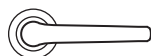

**K00DAS**  
BDC / Latch

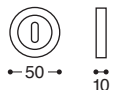
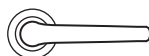

**K00DAP**  
Cle L / Lock

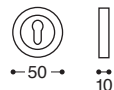

**K00DAY**  
Cle I / Cylinder

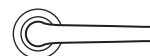

**K00DAW**  
Cond/Dec C. 6/7/8 / Privacy

**Minerva/HB6 Métal rosace** - avec ressort, carré 7 mm / **Metal rose** - springloaded



**K00D1S**  
BDC / Latch

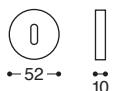

**K00D1P**  
Cle L / Lock

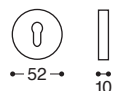

**K00D1Y**  
Cle I / Cylinder

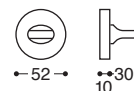

**K00D1W**  
Cond/Dec C. 6/7/8 / Privacy

**Minerva/T11 Métal rosace** - avec ressort, carré 7 mm / **Metal rose** - springloaded

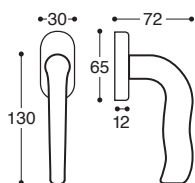

**K00DAI**

Sans main / Without hand

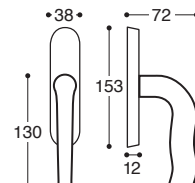

**K00DAK**

Sans main / Without hand

**Minerva DK** Poignée de fenetre  
Mécan. 8 positions / Window handle - 8 pos. mech.

**Minerva Martellina** Poignée de fenetre  
Crémone / Window handle - Cremon

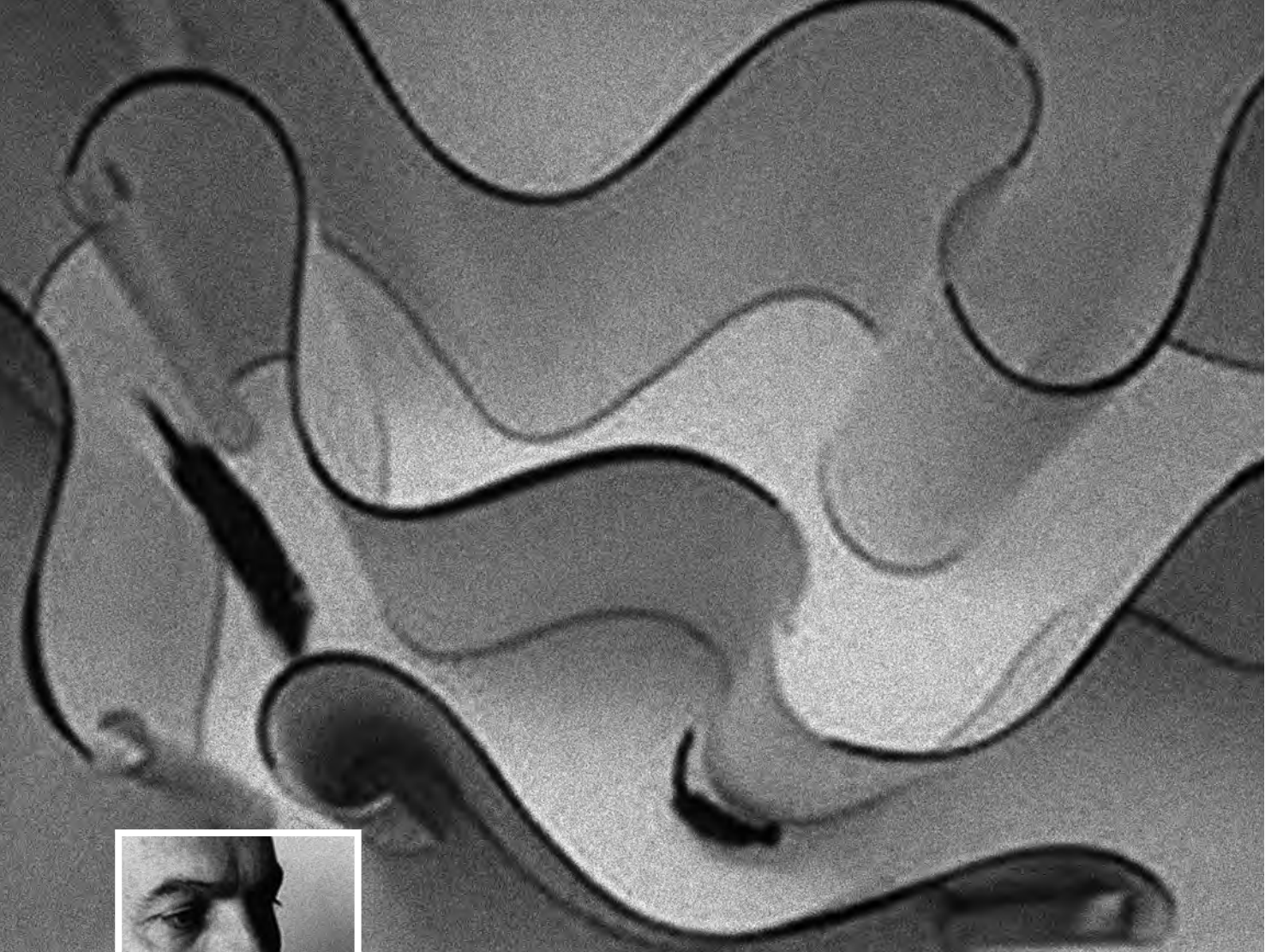

Cartoons 1994



**LUIGI BAROLI**  
ARCHITETTO

Luigi Baroli nasce nel 1951 a Corbetta (Milano). Dopo la laurea in Architettura presso il Politecnico di Milano, si occupa prevalentemente di architettura d'interni, orientandosi anche verso il design del gioiello. Ha curato l'immagine coordinata della catena di negozi di abbigliamento Boggi. Nel 1995 gli viene assegnato il Compasso d'Oro per il progetto del paravento Cartoons realizzato da Baleri Italia, azienda con la quale collabora dal 1988 curando la direzione artistica dello showroom di Milano e gli allestimenti della collezione in Italia e all'estero. La sua collaborazione con Gloria inizia nel 2001 con la progettazione delle lampade Mouse e Lily. Dal 2004 è partner associato di eb&c Centro Ricerche Enrico Baleri, svolge attività come designer, architetto, esperto di comunicazione e di mode.

Born in 1951 in Corbetta (Milan). After taking an architecture degree at Milan Polytechnic, he began focusing on interior architecture

and jewellery design. He conceived and coordinated the corporate image program of the clothing store chain Boggi. In 1995 he was awarded the Golden Compass for his "Cartoons" screen, produced by Baleri Italia, with whom he has been working since 1988 as artistic director of the Milan showroom and the installations of the collection elsewhere in Italy and abroad. His collaboration with Gloria began in 2001 with his design for the Mouse and Lily lamps. Since 2004 he has been a partner in eb&c Research Center, and continues working as a designer, architect and consultant in the fields fashion and communication.

Luigi Baroli wird 1951 in Corbetta (Mailand) geboren. Nach dem er sein Architekturstudium am den politechnischen Hochschule in Mailand absolviert hat, ist er ausschliesslich im Bereich Innenarchitektur tätig und orientiert sich auch auf das Schmuckdesign. Er hat das brand identity des Modegeschäfts Boggi

gestaltet. 1995 wird er mit dem goldenen Kompass ausgezeichnet für das Projekt des "paravento Cartoons", welches von Baleri Italia realisiert wurde, mit diesem Unternehmen arbeitet er ab 1988 zusammen und ist für die künstlerische Direktion des Showrooms in Mailand und für die Ausstattungen der Sammlungen in Italien und im Ausland zuständig. 2001 beginnt seine Zusammenarbeit mit Gloria mit der Projektgestaltung der Lampen Mouse und Lily. Ab 2004 ist er Partner von eb&c Centro Ricerche Enrico Baleri und ist als Architekt, Designer, Kommunikations- und Modeexperte tätig.

Luigi Baroli est né en 1951 à Corbetta (Milan). Après son diplôme en Architecture à l'École Polytechnique de Milan, il s'occupe principalement d'architecture d'intérieur, en s'orientant également vers le design des bijoux. Il a soigné l'image coordonnée de la chaîne de magasins de vêtements Boggi. En 1995, le prix Compasso d'Oro lui

est décerné pour le projet du paravento. Des dessins animés réalisés par Baleri Italia, une entreprise avec laquelle il collabore depuis 1988 en soignant la direction artistique de la salle d'exposition de Milan et des mises en place de la collection en Italie et à l'extérieur. Sa collaboration avec Gloria Srl commence en 2001 avec la conception des lampes Mouse et Lily. Depuis 2004, il est partenaire associé de eb&c Centre de Recherche Enrico Baleri; il exerce des activités comme designer, architecte, expert en communication et de la mode.



KLEIS



**Tratto.**

2005

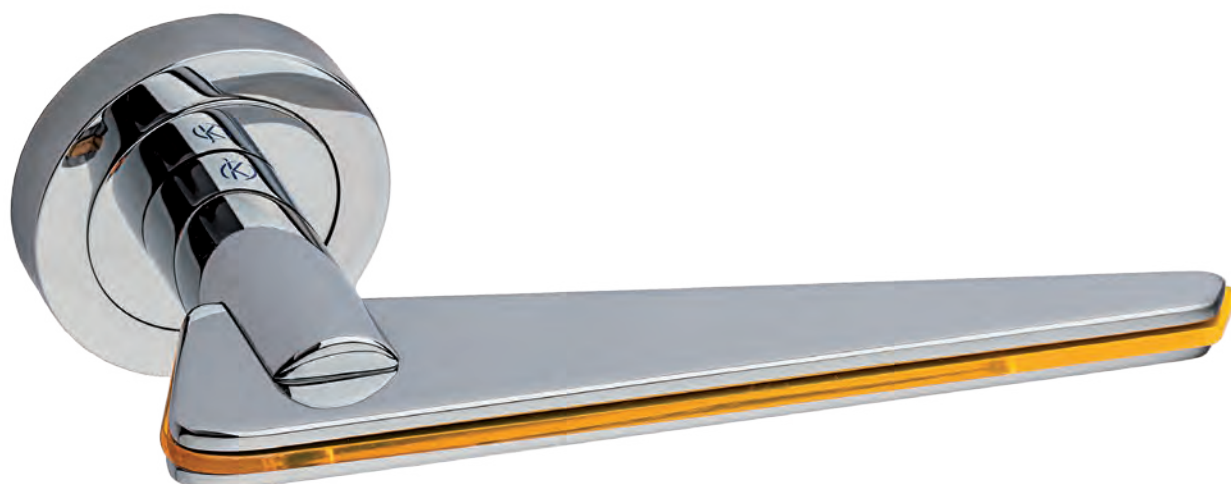

## Tratto.

design Luigi Baroli

materiale / material  
Ottone / Brass

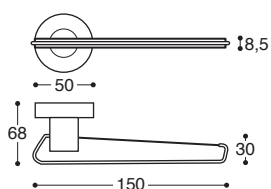

finiture standard / standard finishes



**o6** - Cromo lucido  
Polished chrome



**o8** - Cromo satinato  
Satin chrome

finiture trendy / trendy finishes



**G3** - Gun metal

L'inserto è disponibile nelle varianti di colore  
arancio - trasparente - bianco - nero.

The insert is available in orange - transparent  
- white - black.

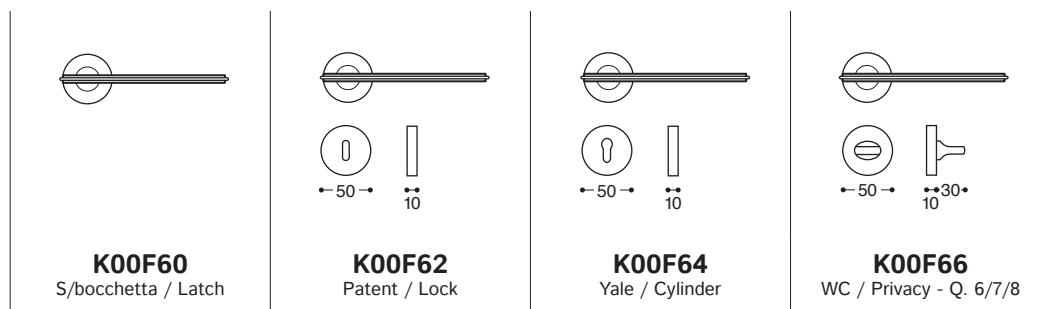

**Tratto/HB14** Rosetta metallo&plastica - con molla / **Metal&plastic rose** - springloaded

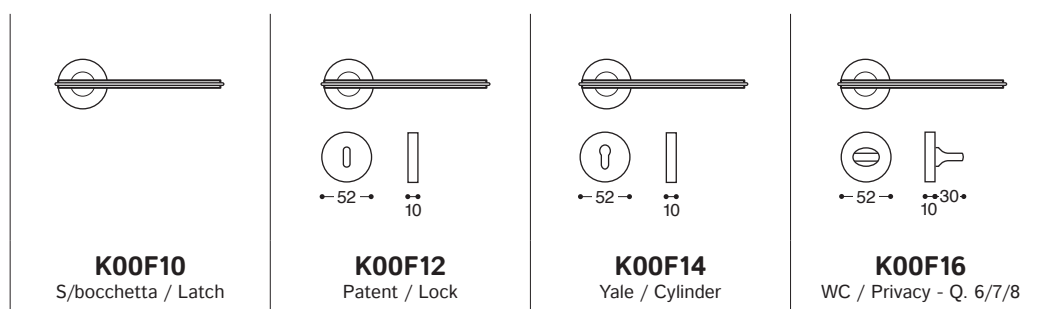

**Tratto/T11** Rosetta metallo - con molla / **Metal rose** - springloaded

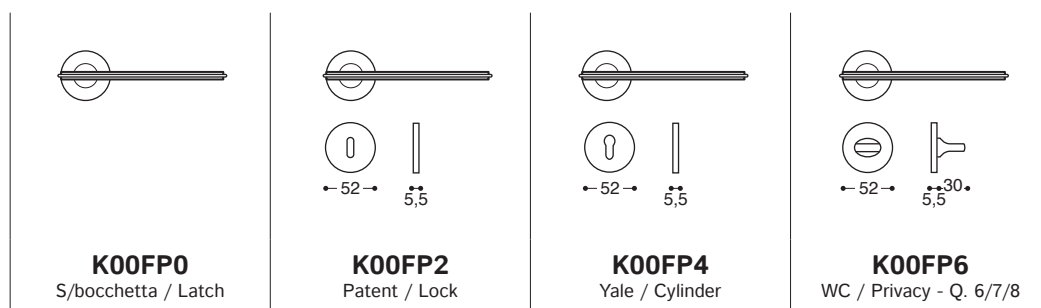

**Tratto/FLT** Rosetta ribassata metallo - con molla / **Metal flat rose** - springloaded

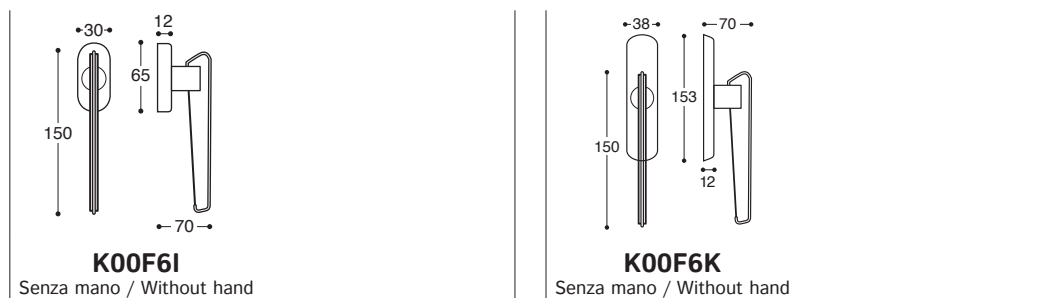

**Tratto DK** - mov. 8 scatti  
Window handle - 8 pos. mech.

**Tratto Martellina**  
Per finestra - Cremonese / For window - Cremon

Material / material  
Messing / Brass

standard 

**Tratto.**  
design Luigi Baroli

Standardveredelungen / standard finishes



**o6** - Chrom  
Polished chrome



**o8** - Chrom matt  
Satin Chrome

Trendy Veredelungen / trendy finishes



**G3** - Gun metal

Der Einsatz ist in den Farbvarianten  
**orange - transparent - weiß -  
schwarz erhältlich.**

The insert is available in orange -  
transparent - white - black.

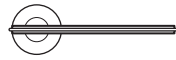

**K00F10**

Ohne Schlüssel / Latch

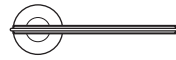

**K00F13**

BB / Lock

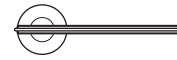

**K00F15**

PZ / Cylinder

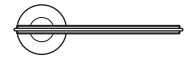

**K00F17**

BAD S. 6/7/8 / Privacy

**Tratto/T11** Türgriff - Metall Rosetten DIN 38 mm - Mit Feder / **Metal rose** - springloaded

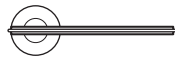

**K00FS0**

Ohne Schlüssel / Latch

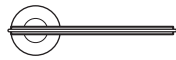

**K00FS3**

BB / Lock

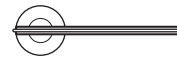

**K00FS5**

PZ / Cylinder

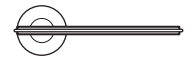

**K00FS7**

BAD S. 6/7/8 / Privacy

**Tratto/52D** Türgriff - Metall/Kunststoff Rosetten DIN 38 mm - Mit Feder  
**Metal&plastic rose** - springloaded

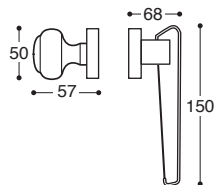

**K00F1D**

PZ, Links / LH

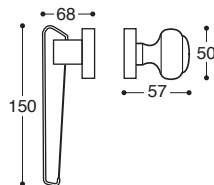

**K00F1C**

PZ, Rechts / RH

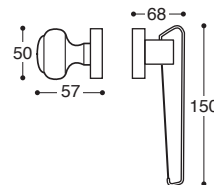

**K00FSD**

PZ, Links / LH

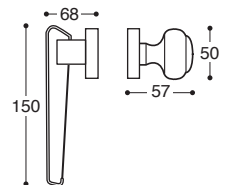

**K00FSC**

PZ, Rechts / RH

**Tratto/T11**  
**Metall Rosetten** - Wechselgarnitur

**Tratto/52D**  
**Metall/Kunststoff Rosetten** - Wechselgarnitur

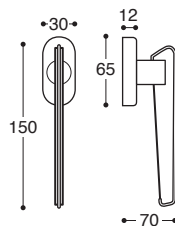

**K00F61**

Ohne Hand / Without hand

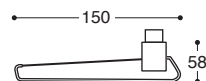

**K00F09**

Links / LH

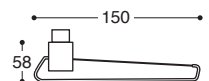

**K00F08**

Rechts / RH

**Tratto DK** Fenstergriffe - Mit Rastung  
Window handle - 8 pos. mech.

**Tratto**  
Drückerlochteil - Ohne Rosetten

matériau / material  
Laiton / Brass

standard 

**Tratto.**  
design Luigi Baroli

finitions standards / standard finishes



**o6** - Chrome poli  
Polished chrome



**o8** - Chrome satiné  
Satin chrome

finitions trendy / trendy finishes



**G3** - Gun metal

L'insertion est disponible dans les variantes de couleur orange - transparent - blanc - noir.

The insert is available in orange - transparent - white - black.



**K00F6S**  
BDC / Latch

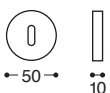

**K00F6P**  
Cle L / Lock

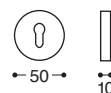

**K00F6Y**  
Cle I / Cylinder

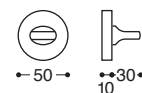

**K00F6W**  
Cond/Dec C. 6/7/8 / Privacy

**Tratto/HB14** Métal et plastique rosace - avec ressort, carré 7 mm / **Metal&plastic rose** - springloaded



**K00F1S**  
BDC / Latch

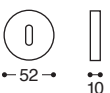

**K00F1P**  
Cle L / Lock

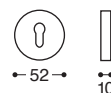
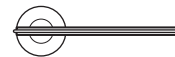

**K00F1Y**  
Cle I / Cylinder

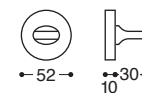
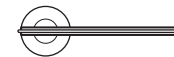

**K00F1W**  
Cond/Dec C. 6/7/8 / Privacy

**Tratto/T11** Métal rosace - avec ressort, carré 7 mm / **Metal rose** - springloaded



**K00FPS**  
BDC / Latch



**K00FPP**  
Cle L / Lock

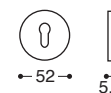
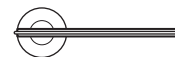

**K00FPY**  
Cle I / Cylinder

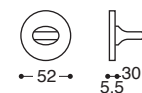
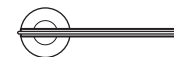

**K00FPW**  
Cond/Dec C. 6/7/8 / Privacy

**Tratto/FLT** Rosette abaissée métal - avec ressort, carré 7 mm / **Metal flat rose** - springloaded

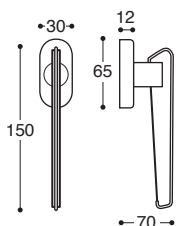

**K00F6I**  
Sans main / Without hand

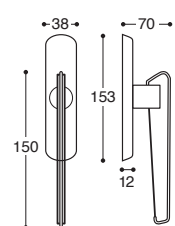

**K00F6K**  
Sans main / Without hand

**Tratto DK** Poignée de fenêtre  
Mécan. 8 positions / Window handle - 8 pos. mech.

**Tratto Martellina** Poignée de fenêtre  
Crémone / Window handle - Cremona



## Tratto Quadra.

design Luigi Baroli

materiale / material  
Ottone / Brass

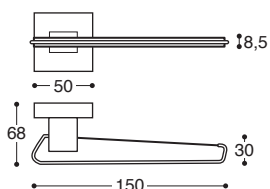

finiture standard / standard finishes



**08** - Cromo satinato  
Satin chrome



**88** - Bi-Cromo  
Polished + satin chrome

finiture trendy / trendy finishes



**G3** - Gun metal

L'inserto è disponibile nelle varianti di colore  
arancio - trasparente - bianco - nero.

The insert is available in orange - transparent  
- white - black.

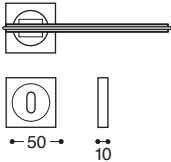
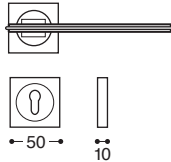
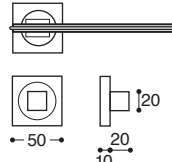
 <p><b>K00T50</b> S/bocchetta / Latch</p>	 <p><b>K00T52</b> Patent / Lock</p>	 <p><b>K00T54</b> Yale / Cylinder</p>	 <p><b>K00T56</b> WC / Privacy - Q. 6/7/8</p>
--	--	--	--

**Tratto/Quad** Rosetta metallo - con molla / **Metal rose** - springloaded

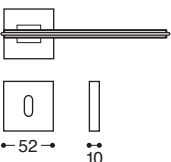
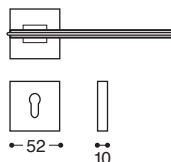
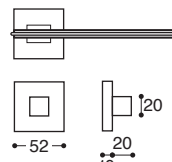
 <p><b>K00TV0</b> S/bocchetta / Latch</p>	 <p><b>K00TV2</b> Patent / Lock</p>	 <p><b>K00TV4</b> Yale / Cylinder</p>	 <p><b>K00TV6</b> WC / Privacy - Q. 6/7/8</p>
--	--	--	--

**Tratto/Q11** Rosetta metallo - con molla / **Metal rose** - springloaded

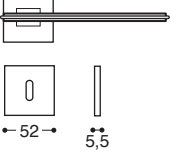
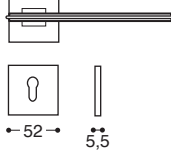
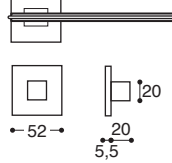
 <p><b>K00TF0</b> S/bocchetta / Latch</p>	 <p><b>K00TF2</b> Patent / Lock</p>	 <p><b>K00TF4</b> Yale / Cylinder</p>	 <p><b>K00TF6</b> WC / Privacy - Q. 6/7/8</p>
--	--	--	--

**Tratto/FLQ** Rosetta ribassata metallo - con molla / **Metal flat rose** - springloaded

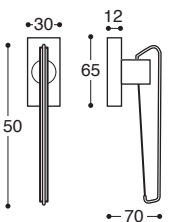
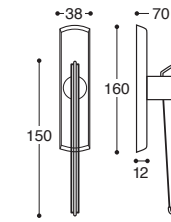
 <p><b>K00T51</b> Senza mano / Without hand</p>	 <p><b>K00T5K</b> Senza mano / Without hand</p>
--	--

**Tratto DK** - mov. 8 scatti  
Window handle - 8 pos. mech.

**Tratto Martellina**  
Per finestra - Cremonese / For window - Cremon

Material / material  
Messing / Brass

standard



**Tratto Quadra.**  
design Luigi Baroli

Standardveredelungen / standard finishes



**o6** - Chrom  
Polished chrome



**o8** - Chrom matt  
Satin chrome

Trendy Veredelungen / trendy finishes



**G3** - Gun metal

Der Einsatz ist in den Farbvarianten  
**orange - transparent - weiß -  
schwarz** erhältlich.

The insert is available in orange -  
transparent - white - black.

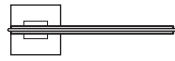

**K00TV0**  
Ohne Schlüssel / Latch

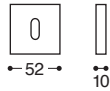
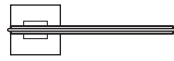

**K00TV3**  
BB / Lock

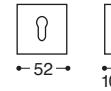
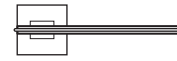

**K00TV5**  
PZ / Cylinder

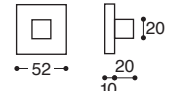
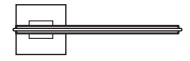

**K00TV7**  
BAD S. 6/7/8 / Privacy

**Tratto Quad/Q11** Türgriff - Metall Rosetten DIN 38 mm - Mit Feder / **Metal rose** - springloaded

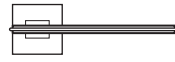

**K00TB0**  
Ohne Schlüssel / Latch

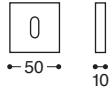
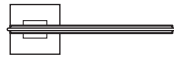

**K00TB3**  
BB / Lock

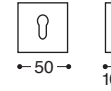
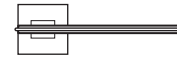

**K00TB5**  
PZ / Cylinder

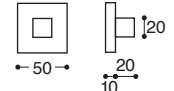
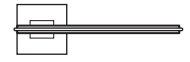

**K00TB7**  
BAD S. 6/7/8 / Privacy

**Tratto Quad/50x50** Türgriff - Metall/Kunststoff Rosetten DIN 38 mm - Mit Feder  
**Metal&plastic rose** - springloaded

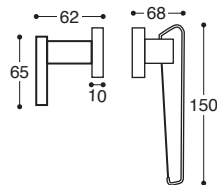

**K00TVD**  
PZ, Links / LH

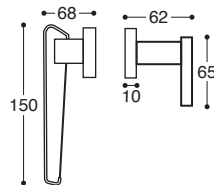

**K00TVC**  
PZ, Rechts / RH

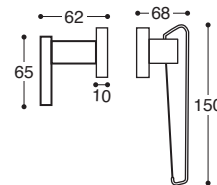

**K00TBD**  
PZ, Links / LH

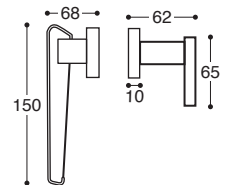

**K00TBC**  
PZ, Rechts / RH

**Tratto Quad/Q11**  
Metall Rosetten - Wechselgarnitur

**Tratto Quad/50x50**  
Metall/Kunststoff Rosetten - Wechselgarnitur

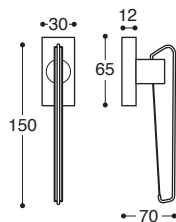

**K00T71**  
Ohne Hand/ Without hand

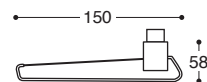

**K00T09**  
Links / LH

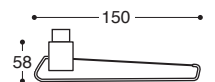

**K00T08**  
Rechts / RH

**Tratto Quad dk** Fenstergriffe  
Mit Rastung / Window handle - 8 pos. mech.

**Tratto Quad**  
Drückerlochteil - Ohne Rosetten



matériau / material  
Laiton / Brass

standard 

**Tratto Quadra.**  
design Luigi Baroli

finitions standards / standard finishes



**08** - Chrome satiné  
Satin chrome



**88** - Chrome poli + satiné  
Polished + satin chrome

finitions trendy / trendy finishes



**G3** - Gun metal

L'insertion est disponible dans les variantes de couleur orange - transparent - blanc - noir.

The insert is available in orange - transparent - white - black.



**K00T5S**  
BDC / Latch

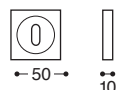

**K00T5P**  
Cle L / Lock

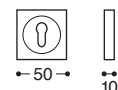
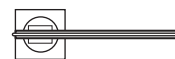

**K00T5Y**  
Cle I / Cylinder

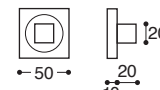

**K00T5W**  
Cond/Dec C. 6/7/8 / Privacy

**Tratto/Quad Métal rosace** - avec ressort, carré 7 mm / **Metal rose** - springloaded

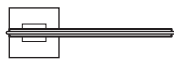

**K00TVS**  
BDC / Latch

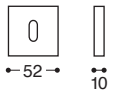
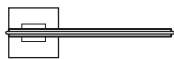

**K00TVP**  
Cle L / Lock

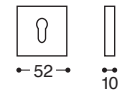

**K00TVY**  
Cle I / Cylinder

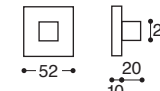
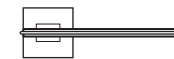

**K00TVW**  
Cond/Dec C. 6/7/8 / Privacy

**Tratto/Q11 Métal rosace** - avec ressort, carré 7 mm / **Metal rose** - springloaded



**K00TFS**  
BDC / Latch

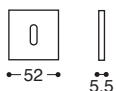

**K00TFP**  
Cle L / Lock

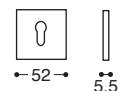

**K00TFY**  
Cle I / Cylinder

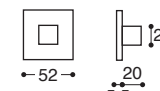

**K00TFW**  
Cond/Dec C. 6/7/8 / Privacy

**Tratto/FLQ Rosette abaissée métal** - avec ressort, carré 7 mm / **Metal flat rose** - springloaded

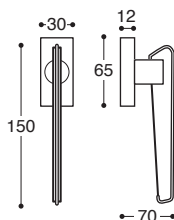

**K00T5I**

Sans main / Without hand

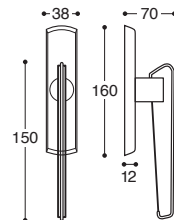

**K00T5K**

Sans main / Without hand

**Tratto DK** Poignée de fenetre  
Mécan. 8 positions / Window handle - 8 pos. mech.

**Tratto Martellina** Poignée de fenetre  
Crémone / Window handle - Cremon

## Come ordinare - How to order - Wie bestellen - Comment commander

CODICE D'ACQUISTO\* - PURCHASING CODE\* - BESTELLNUMMER\* - CODE D'ACHAT\*



### ESEMPIO / EXAMPLE / BEISPIEL / EXEMPLE:

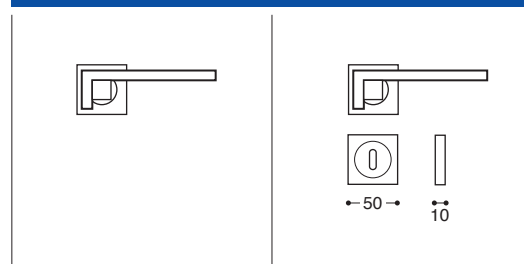

<b>CODICE</b> CODE KODE CODE	S/bocchetta / Latch	<b>K00M5</b>	<b>2</b>	<b>VERSIONE</b> FUNCTION FUNKTION VERSION
		Patent / Lock		
	<b>Grafite/Quad</b>			

materiale / material

**Alluminio-ottone**  
**Aluminum-brass**

finiture disponibili  
finish available:

**FINITURA**  
FINISH  
FARBE  
FINITION

- GC** - Grafite + cromo  
Graphite + polished chrome
- 69** - Nikmat + cromo  
Nikmat + polished chrome
- PC** - Perla + cromo  
Silver + polished chrome

\*Nel caso non fossero presenti tutti i tre riferimenti, usare in sequenza quelli/quello evidenziati.

\*In case they were not all three references, use in sequence those/that highlighted.

\*Für den Fall Sie nicht alle drei Referenzen finden sollten, schreiben sie sequentiellen.

\*Dans le cas où ils ne sont pas tous les trois références, utilisent séquentiels / une évidence.

## Accessori di complemento

Complementary accessories / Einrichtungszubehör / Accessoires

Maniglioni / Pull / Türgriff / Tirants 98

## Accessori maniglia

Handle accessories / Griffzubehör / Accessoires poignées

<b>Rosette tonde / Round roses</b> <b>Runde Rosetten / Rosaces arrondies</b>	con sistema / with system / mit System / Avec système	
	<b>HB6</b>	Ø 50 mm - 10 mm spessore/thickness/Stärke/épaisseur <span style="float: right;">99</span>
	<b>T11</b>	Ø 52 mm - 10 mm spessore/thickness/Stärke/épaisseur <span style="float: right;">100</span>
	<b>HB14</b>	Ø 50 mm - 10 mm spessore/thickness/Stärke/épaisseur <span style="float: right;">102</span>
	<b>HB11</b>	Ø 48 mm - 10 mm spessore/thickness/Stärke/épaisseur <span style="float: right;">104</span>
	<b>FLT</b>	Ø 52 mm - 5,5 mm spessore/thickness/Stärke/épaisseur <span style="float: right;">105</span>

<b>Rosette quadre / Squared roses</b> <b>Quadratische Rosetten</b> <b>Rosaces carrés</b>	con sistema / with system / mit System / Avec système	
	<b>Q11</b>	52x52 mm - 10 mm spessore/thickness/Stärke/épaisseur <span style="float: right;">106</span>
	<b>QUAD</b>	50x50 mm - 10 mm spessore/thickness/Stärke/épaisseur <span style="float: right;">108</span>
	<b>FLQ</b>	52x52 mm - 5,5 mm spessore/thickness/Stärke/épaisseur <span style="float: right;">109</span>

<b>Rosette speciali / Specials roses</b> <b>Besondere Rosetten</b> <b>Rosaces spéciales</b>	<b>APRITI/SESAMO</b>	Ø 52 mm - 8 mm spessore/thickness/Stärke/épaisseur <span style="float: right;">110</span>
	<b>FEDRA</b>	Ø 50 mm - 12 mm spessore/thickness/Stärke/épaisseur <span style="float: right;">112</span>

<b>Rosette ovali e rettangolari</b> <b>Oval and rectangular roses</b> <b>Ovale und rechteckige Rosetten</b> <b>Rosaces ovales et rectangulaires</b>	<b>OVALE</b>	31x62 mm - 10 mm spessore/thickness/Stärke/épaisseur <span style="float: right;">113</span>
	<b>RETTANGOLARE</b>	31x62 mm - 10 mm spessore/thickness/Stärke/épaisseur <span style="float: right;">114</span>

<b>Serramenti / Window frames</b> <b>Fenster und Türen / Serrures</b>	<b>DK</b>	30x65 mm - 12 mm spessore/thickness/Stärke/épaisseur <span style="float: right;">115</span>
	<b>DKR</b>	30x65 mm - 12 mm spessore/thickness/Stärke/épaisseur <span style="float: right;">115</span>
	<b>CREMONESE</b>	<span style="float: right;">115</span>

Finiture disponibili / Finishes available  
 Verfügbare Veredelungen / Finitions disponibles 117

## Maniglioni / Pull / Türgriff / Tirants La



**06**

**08**

**22**

**33**

**SL**

**BA**

**G3**

**15**

**16**

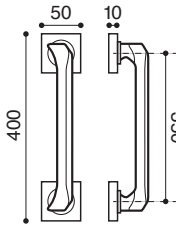
  
**K00HWM**  
 Maniglione  
 Fiss. frontale  
 o passante  
 Single pull  
 Face/passing fix.  
 Einzel Türgriff  
 Tirant

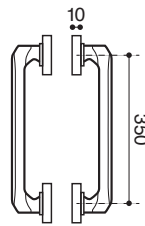
  
**K00HWT**  
 Paio maniglioni  
 Fiss. frontale  
 o passante  
 Pull set  
 Face/passing fix.  
 Türgriff (paar weise)  
 Paire de tirants

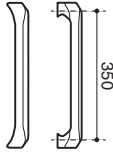
  
**K00HWC**  
 Maniglione  
 Fiss. frontale  
 o passante  
 Single pull  
 Face/passing fix.  
 Einzel Türgriff  
 Tirant

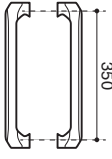
  
**K00HWD**  
 Paio maniglioni  
 Fiss. frontale  
 o passante  
 Pull set  
 Face/passing fix.  
 Türgriff (paar weise)  
 Paire de tirants

standard 

finiture standard / standard finishes  
Standardveredelungen / finitions standards

<b>06</b> - Cromo lucido / Polished chrome Chrom / Chrome poli	•	•	•	•
<b>08</b> - Cromo satinato / Satin chrome Chrom matt / Chrome satiné	•	•	•	•
<b>22</b> - Nickel lucido / Polished nickel Nickel / Nickel poli	•	•	•	•
<b>33</b> - Nickel satinato vern. / Sat. nickel Nickel / Nickel satiné	•	•	•	•
<b>SL</b> - Silver / Silber	•	•	•	•
<b>BA</b> - Bronzo gr. opaco / Mat sat. bronze Matt Sat. Bronze / Bronze mat sat.	•	•	•	•

finiture trendy / trendy finishes  
Trendy Veredelungen / finitions trendy

<b>G3</b> - Gun metal	•	•	•	•
<b>15</b> - Nero opaco* / Mat black* Matt schwarz* / Noir mat*	•	•	•	•
<b>16</b> - Bianco* / White* Weiß* / Blanc*	•	•	•	•

**La** Maniglioni / Pull / Türgriff / Tirants      350 mm      350-UG      350 mm      350-UG

\* a richiesta / on demand / auf Anfrage / sur demande



**06**

**08**

**33**

**BA**

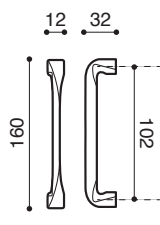
  
**K5116102**  
 Maniglia per mobili  
 Furniture handle  
 int 102 mm

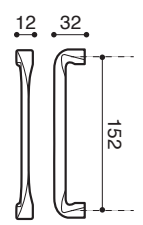
  
**K5116152**  
 Maniglia per mobili  
 Furniture handle  
 int 152 mm

standard 

Fissaggio maniglioni / Pulls installation  
Tuergriffen Befestigung / Montage des tirants

**La** Maniglioni / Pull / Türgriff / Tirants

**La - 4**

**La - 6**

vedi pag. \_\_\_\_\_ 121  
see page / Siehe Seite / voir pag.

## Rosette tonda / Round roses / Rosaces arrondies HB6 sistema / system / système

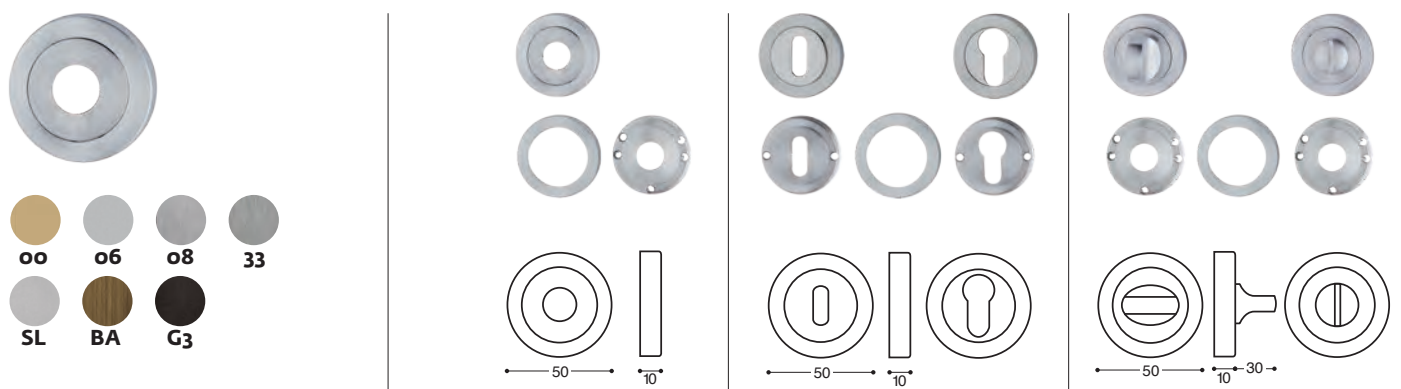

**oo** **o6** **o8** **33**  
**SL** **BA** **G3**

**Rosetta**  
**Rose**  
**Rosace**  
**RHB6X0**

**Bocchetta**  
**Escutcheon**  
**Rosace de cle**  
**R13717** (Patent / Lock Cle L) | **R13719** (Yale / Cylinder Cle I)

**WC**  
**Privacy**  
**Cond/Dec**  
**R89600**

finiture standard / standard finishes  
 finitions standards

<b>oo</b> - Oro / Polished brass Laiton poli	•	•	•	•
<b>o6</b> - Cromo lucido / Polish. chrome Chrome poli	•	•	•	•
<b>o8</b> - Cromo satinato / Sat. chrome Chrome satiné	•	•	•	•
<b>33</b> - Nickel sat. vern. / Satin nickel Nickel satiné	•	•	•	•
<b>SL</b> - Silver	•	•	•	•
<b>BA</b> - Bronzo gr. opaco Mat satin bronze Bronze mat satiné	•	•	•	•

finiture trendy / trendy finishes  
 finitions trendy

<b>G3</b> - Gun metal	•	•	•	•
-----------------------	---	---	---	---

**HB6**

**HB6**

**HB6/WC**



## Rosette tonde / Round roses / Rosaces arrondies T11 sistema / system / système

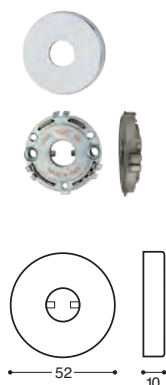
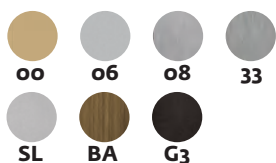

**Rosetta  
Rose  
Rosace**

**RT11X0**



**Bocchetta  
Escutcheon  
Rosace de cle**

Patent / Lock  
Cle L

**R13037**

Yale / Cylinder  
Cle I

**R13038**



**WC  
Privacy  
Cond/Dec**

**R18751**



finiture standard / standard finishes  
finitions standards

<b>oo</b> - Oro / Polished brass Laiton poli	•	•	•	•
<b>o6</b> - Cromo lucido / Polish. chrome Chrome poli	•	•	•	•
<b>o8</b> - Cromo satinato / Sat. chrome Chrome satiné	•	•	•	•
<b>33</b> - Nickel sat. vern. / Satin nickel Nickel satiné	•	•	•	•
<b>SL</b> - Silver	•	•	•	•
<b>BA</b> - Bronzo gr. opaco Mat satin bronze Bronze mat satiné	•	•	•	•

finiture trendy / trendy finishes  
finitions trendy

<b>G3</b> - Gun metal	•	•	•	•
-----------------------	---	---	---	---

**T11**

**T11**

**T11/WC**



Base con molla premontata  
Base with pre-assembled spring  
Base avec ressort prémonté

## Runde Rosetten T11-System



standard 

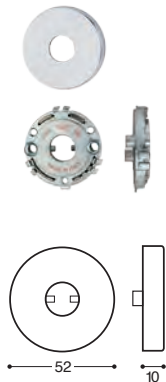

**Rosetten**  
DIN 38 mm

**RT11X3**

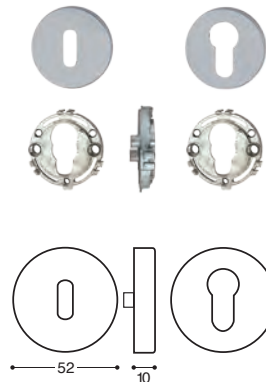

**Schlüsser rosetten**  
DIN 38 mm

BB	PZ
<b>R13044</b>	<b>R13045</b>



**Bad**  
DIN 38 mm

**R18759**

### Standardveredelungen

<b>oo</b> - Messing poliert	•	•	•	•
<b>o6</b> - Chrom	•	•	•	•
<b>o8</b> - Chrom matt	•	•	•	•
<b>33</b> - Nickel matt	•	•	•	•
<b>SL</b> - Silber	•	•	•	•
<b>BA</b> - Matt satin Bronze	•	•	•	•

### Trendy Veredelungen

<b>G3</b> - Gun metal	•	•	•	•
-----------------------	---	---	---	---

**T11**

**T11**

**T11/WC**



Basis mit vormontierter Feder

## Rosette tonde / Round roses / Rosaces arrondies HB14 sistema / system / système

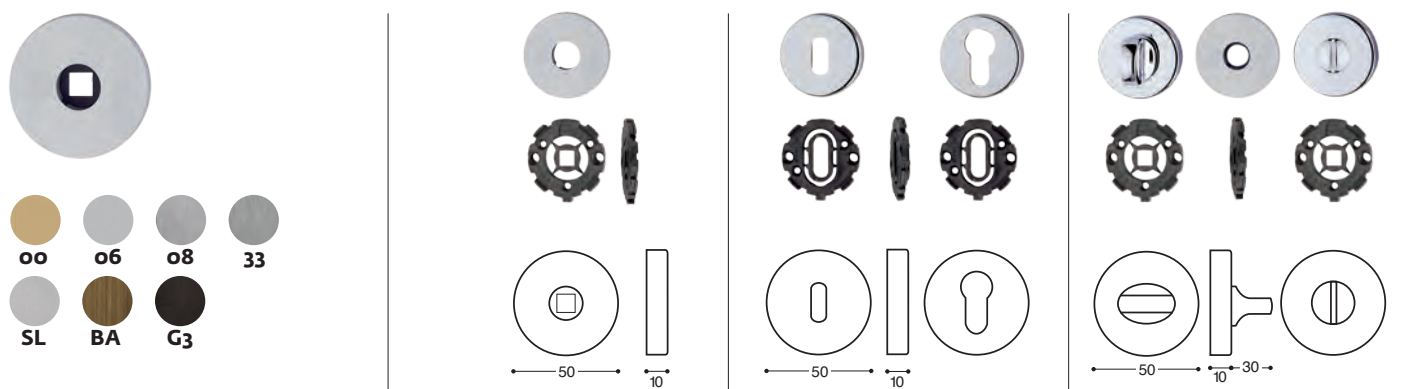



**oo** **o6** **o8** **33**  
**SL** **BA** **G3**

**Rosetta**  
**Rose**  
**Rosace**  
**RHB140**

**Bocchetta**  
**Escutcheon**  
**Rosace de cle**  
**R13700**      **R13701**

**WC**  
**Privacy**  
**Cond/Dec**  
**R89660**

**standard**  

finiture standard / standard finishes  
finitions standards

<b>oo</b> - Oro / Polished brass Laiton poli	•	•	•	•
<b>o6</b> - Cromo lucido / Polish. chrome Chrome poli	•	•	•	•
<b>o8</b> - Cromo satinato / Sat. chrome Chrome satiné	•	•	•	•
<b>33</b> - Nickel sat. vern. / Satin nickel Nickel satiné	•	•	•	•
<b>SL</b> - Silver	•	•	•	•
<b>BA</b> - Bronzo gr. opaco Mat satin bronze Bronze mat satiné	•	•	•	•

finiture trendy / trendy finishes  
finitions trendy

<b>G3</b> - Gun metal	•	•	•	•
-----------------------	---	---	---	---

**HB14**

**HB14**

**HB14/WC**





## Runde Rosetten HB14-System

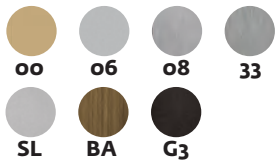

standard



**Rosetten**  
DIN 38 mm

**RHB143**

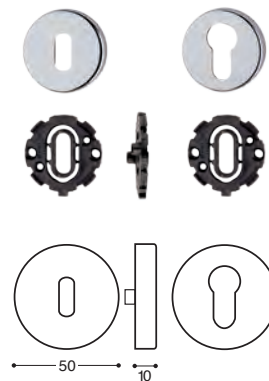

**Schlüssen rosetten**  
DIN 38 mm

BB	PZ
<b>R13702</b>	<b>R13703</b>

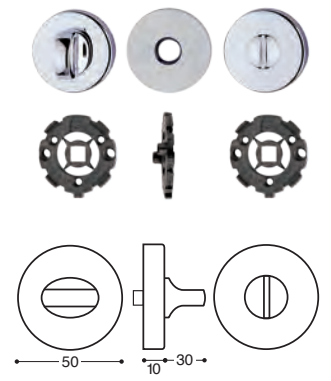

**Bad**  
DIN 38 mm

**R89663**

### Standardveredelungen

<b>oo</b> - Messing poliert	•	•	•	•
<b>o6</b> - Chrom	•	•	•	•
<b>o8</b> - Chrom matt	•	•	•	•
<b>33</b> - Nickel matt	•	•	•	•
<b>SL</b> - Silber	•	•	•	•
<b>BA</b> - Matt satin Bronze	•	•	•	•

### Trendy Veredelungen

<b>G3</b> - Gun metal	•	•	•	•
-----------------------	---	---	---	---

**HB14**

**HB14**

**HB14/WC**



## Rosette tonde / Round roses / Rosaces arrondies HB11 Sistema / System / Système

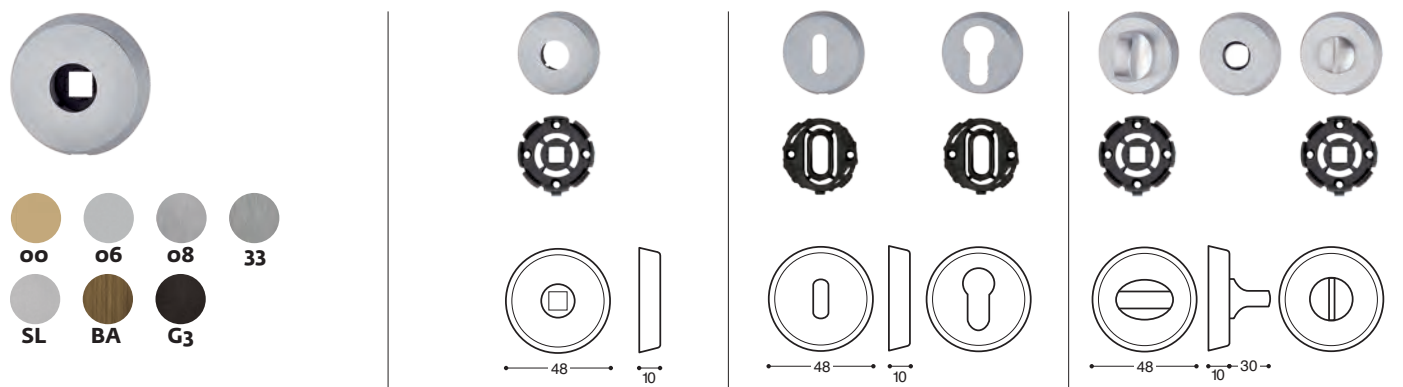

**oo** **o6** **o8** **33**  
**SL** **BA** **G3**

**Rosetta**  
**Rose**  
**Rosace**  
**RHB110**

**Bocchetta**  
**Escutcheon**  
**Rosace de cle**  
**R13705** (Patent / Lock Cle L) | **R13707** (Yale / Cylinder Cle I)

**WC**  
**Privacy**  
**Cond/Dec**  
**R89640**



finiture standard / standard finishes  
finitions standards

<b>oo</b> - Oro / Polished brass Laiton poli	•	•	•	•
<b>o6</b> - Cromo lucido / Polish. chrome Chrome poli	•	•	•	•
<b>o8</b> - Cromo satinato / Sat. chrome Chrome satiné	•	•	•	•
<b>33</b> - Nickel sat. vern. / Satin nickel Nickel satiné	•	•	•	•
<b>SL</b> - Silver	•	•	•	•
<b>BA</b> - Bronzo gr. opaco Mat satin bronze Bronze mat satiné	•	•	•	•

finiture trendy / trendy finishes  
finitions trendy

<b>G3</b> - Gun metal	•	•	•	•
-----------------------	---	---	---	---

**HB11**

**HB11**

**HB11/WC**



## Rosette tonda / Round roses / Rosaces arrondies FLT sistema / system / système

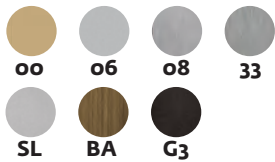

**Rosetta  
Rose  
Rosace**

**RFLTX0**

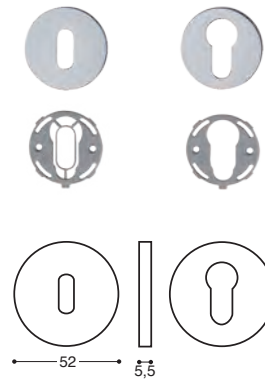

**Bocchetta  
Escutcheon  
Rosace de cle**

Patent / Lock  
Cle L

**R13035**

Yale / Cylinder  
Cle I

**R13036**

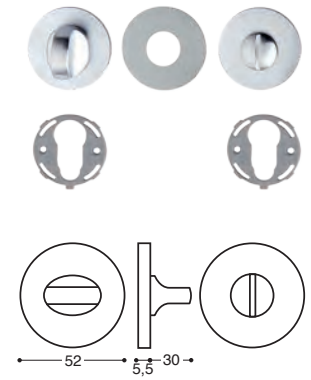

**WC  
Privacy  
Cond/Dec**

**R896FT**



finiture standard / standard finishes  
finitions standards

<b>oo</b> - Oro / Polished brass Laiton poli	•	•	•	•
<b>o6</b> - Cromo lucido / Polish. chrome Chrome poli	•	•	•	•
<b>o8</b> - Cromo satinato / Sat. chrome Chrome satiné	•	•	•	•
<b>33</b> - Nickel sat. vern. / Satin nickel Nickel satiné	•	•	•	•
<b>SL</b> - Silver	•	•	•	•
<b>BA</b> - Bronzo gr. opaco Mat satin bronze Bronze mat satiné	•	•	•	•

finiture trendy / trendy finishes  
finitions trendy

<b>G3</b> - Gun metal	•	•	•	•
-----------------------	---	---	---	---

**FLT**

**FLT**

**FLT/WC**



Base con molla premontata  
Base with pre-assembled spring  
Base avec ressort prémonté

## Rosette quadrate / Squared roses / Rosaces carrés Q11 sistema / system / système

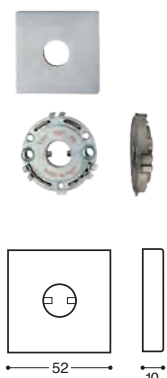
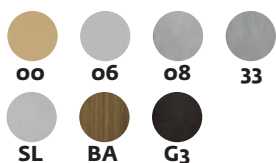

**Rosetta  
Rose  
Rosace**

**RQ11X0**

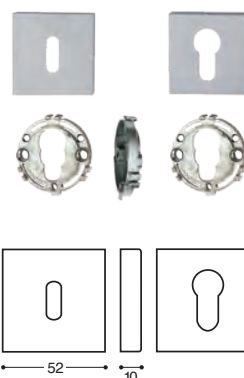

**Bocchetta  
Escutcheon  
Rosace de cle**

Patent / Lock  
Cle L

**R13030**

Yale / Cylinder  
Cle I

**R13031**

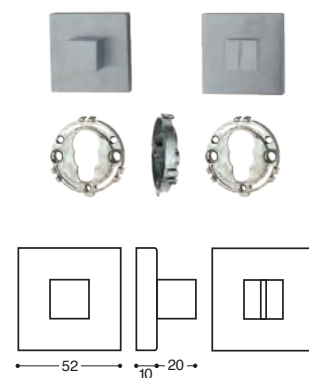

**WC  
Privacy  
Cond/Dec**

**R18753**

finiture standard / standard finishes  
finitions standards

<b>oo</b> - Oro / Polished brass Laiton poli	•	•	•	•
<b>o6</b> - Cromo lucido / Polish. chrome Chrome poli	•	•	•	•
<b>o8</b> - Cromo satinato / Sat. chrome Chrome satiné	•	•	•	•
<b>33</b> - Nickel sat. vern. / Satin nickel Nickel satiné	•	•	•	•
<b>SL</b> - Silver	•	•	•	•
<b>BA</b> - Bronzo gr. opaco Mat satin bronze Bronze mat satiné	•	•	•	•

finiture trendy / trendy finishes  
finitions trendy

<b>G3</b> - Gun metal	•	•	•	•
-----------------------	---	---	---	---

**Q11**

**Q11**

**Q11/WC**



Base con molla premontata  
Base with pre-assembled spring  
Base avec ressort prémonté

## Quadratische Rosetten Q11-System



standard

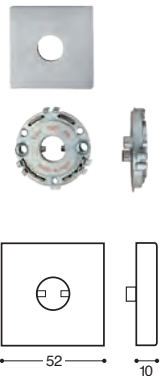

**Rosetten**  
DIN 38 mm

**RQ11X3**

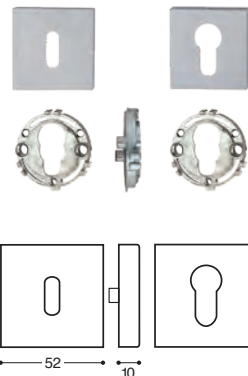

**Schlüssen rosetten**  
DIN 38 mm

BB	PZ
<b>R13048</b>	<b>R13049</b>

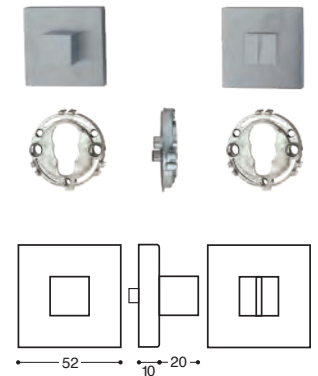

**Bad**  
DIN 38 mm

**R18762**

### Standardveredelungen

<b>oo</b> - Messing poliert	•	•	•	•
<b>o6</b> - Chrom	•	•	•	•
<b>o8</b> - Chrom matt	•	•	•	•
<b>33</b> - Nickel matt	•	•	•	•
<b>SL</b> - Silber	•	•	•	•
<b>BA</b> - Matt satin Bronze	•	•	•	•

### Trendy Veredelungen

<b>G3</b> - Gun metal	•	•	•	•
-----------------------	---	---	---	---

**Q11**

**Q11**

**Q11/WC**

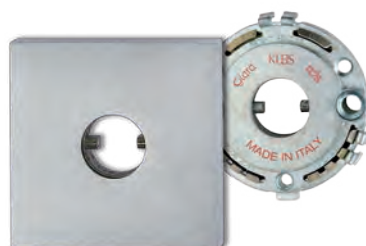

Basis mit vormontierter Feder

## Rosette quadrata / Squared roses / Rosaces carrés QUAD sistema / system / système

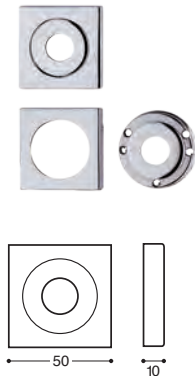

**Rosetta  
Rose  
Rosace**

**RQUAD0**

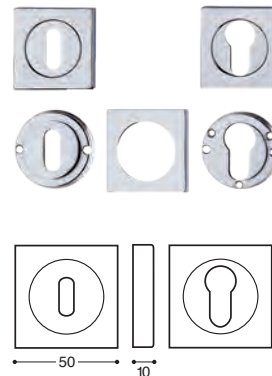

**Bocchetta  
Escutcheon  
Rosace de cle**

Patent / Lock  
Cle L

**R13052**

Yale / Cylinder  
Cle I

**R13053**

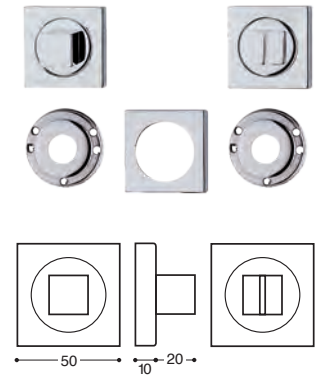

**WC  
Privacy  
Cond/Dec**

**R18750**



finiture standard / standard finishes  
finitions standards

<b>oo</b> - Oro / Polished brass Laiton poli	•	•	•	•
<b>o6</b> - Cromo lucido / Polish. chrome Chrome poli	•	•	•	•
<b>o8</b> - Cromo satinato / Sat. chrome Chrome satiné	•	•	•	•
<b>33</b> - Nickel sat. vern. / Satin nickel Nickel satiné	•	•	•	•
<b>SL</b> - Silver	•	•	•	•
<b>BA</b> - Bronzo gr. opaco Mat satin bronze Bronze mat satiné	•	•	•	•

finiture trendy / trendy finishes  
finitions trendy

<b>G3</b> - Gun metal	•	•	•	•
-----------------------	---	---	---	---

**QUAD**

**QUAD**

**QUAD/WC**





## Rosette quadrata / Squared roses / Rosaces carrés FLQ sistema / system / système

**Finishes:**  
 oo Oro / Polished brass / Laiton poli  
 o6 Cromo lucido / Polish. chrome / Chrome poli  
 o8 Cromo satinato / Sat. chrome / Chrome satiné  
 33 Nickel sat. vern. / Satin nickel / Nickel satiné  
 SL Silver  
 BA Bronzo gr. opaco / Mat satin bronze / Bronze mat satiné  
 G3 Gun metal

**Dimensions:**  
 Rosetta: 52mm x 5,5mm  
 Bocchetta: 52mm x 5,5mm  
 WC Privacy: 52mm x 5,5mm x 20mm

Model	Patent / Lock Cle L	Yale / Cylinder Cle I
Rosetta / Rose / Rosace	R13042	R13043
Bocchetta / Escutcheon / Rosace de cle		
WC Privacy / Cond/Dec		

**standard**  

finiture standard / standard finishes  
finitions standards

oo - Oro / Polished brass Laiton poli	•	•	•	•
o6 - Cromo lucido / Polish. chrome Chrome poli	•	•	•	•
o8 - Cromo satinato / Sat. chrome Chrome satiné	•	•	•	•
33 - Nickel sat. vern. / Satin nickel Nickel satiné	•	•	•	•
SL - Silver	•	•	•	•
BA - Bronzo gr. opaco Mat satin bronze Bronze mat satiné	•	•	•	•

finiture trendy / trendy finishes  
finitions trendy

G3 - Gun metal	•	•	•	•
----------------	---	---	---	---

FLQ

FLQ

FLQ/WC

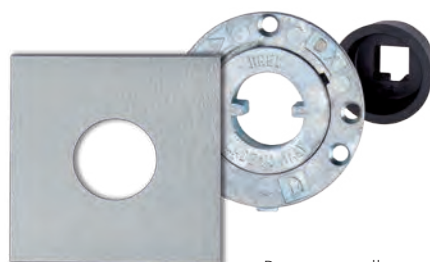

Base con molla premontata  
Base with pre-assembled spring  
Base avec ressort prémonté

## Rosette speciali / Specials roses / Rosaces spéciales Apriti-Sesamo

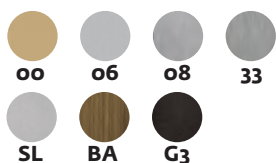

**Rosetta  
Rose  
Rosace**

**KK0000**

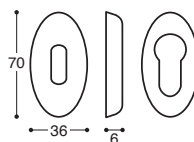

**Bocchetta  
Escutcheon  
Rosace de cle**

Patent / Lock  
Cle L

**K13700**

Yale / Cylinder  
Cle I

**K13701**

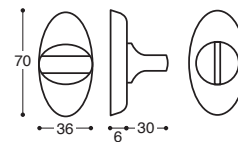

**WC  
Privacy  
Cond/Dec**

**K89690**



finiture standard / standard finishes  
finitions standards

<b>oo</b> - Oro / Polished brass Laiton poli	•	•	•	•
<b>o6</b> - Cromo lucido / Polish. chrome Chrome poli	•	•	•	•
<b>o8</b> - Cromo satinato / Sat. chrome Chrome satiné	•	•	•	•
<b>33</b> - Nickel sat. vern. / Satin nickel Nickel satiné	•	•	•	•
<b>SL</b> - Silver	•	•	•	•
<b>BA</b> - Bronzo gr. opaco Mat satin bronze Bronze mat satiné	•	•	•	•

finiture trendy / trendy finishes  
finitions trendy

<b>G3</b> - Gun metal	•	•	•	•
-----------------------	---	---	---	---

**Apriti-Sesamo**

**Apriti-Sesamo**

**Apriti-Sesamo/WC**





## Besondere Rosetten Apriti-Sesamo



standard



**Rosetten**  
DIN 38 mm

**KK0003**



**Schlüssen rosetten**

BB	PZ
<b>K13700</b>	<b>K13701</b>

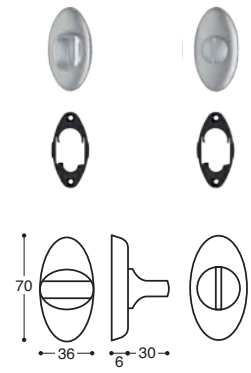

**Bad**

**K89690**

### Standardveredelungen

<b>oo</b> - Messing poliert	•	•	•	•
<b>o6</b> - Chrom	•	•	•	•
<b>o8</b> - Chrom matt	•	•	•	•
<b>33</b> - Nickel matt	•	•	•	•
<b>SL</b> - Silber	•	•	•	•
<b>BA</b> - Matt satin Bronze	•	•	•	•

### Trendy Veredelungen

<b>G3</b> - Gun metal	•	•	•	•
-----------------------	---	---	---	---

**Apriti-Sesamo**

**Apriti-Sesamo**

**Apriti-Sesamo/WC**



## Rosette speciali / Specials roses / Rosaces spéciales Fedra

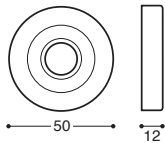
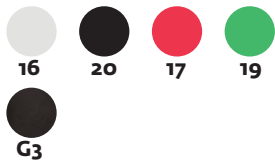

**Rosetta  
Rose  
Rosace**

**RK0050**

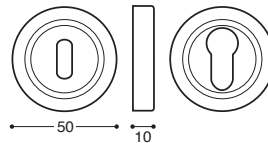

**Bocchetta  
Escutcheon  
Rosace de cle**

Patent / Lock  
Cle L

**R13705**

Yale / Cylinder  
Cle I

**R13707**

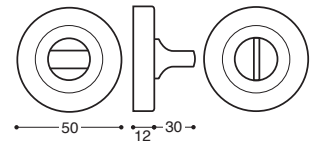

**WC  
Privacy  
Cond/Dec**

**K89920**



finiture standard / standard finishes  
finitions standards

<b>16</b> - Bianco / White Blanc	•	•	•	•
<b>20</b> - Nero / Black Noir	•	•	•	•
<b>17</b> - Rosso / Red Rouge	•	•	•	•
<b>19</b> - Verde / Green Vert	•	•	•	•

**Fedra**

**Fedra**

**Fedra/WC**



## Rosette ovali / Oval roses / Ovale Rosetten / Rosaces ovales

**oo** **o6** **o8** **33**  
**SL** **BA**

**Rosetta / Rose**  
**Rosetten / Rosace**

**RROVAL**

**Bocchetta / Escutcheon**  
**Schlüssen rosetten**  
**Rosace de cle**

Patent / Lock BB / Cle L      Yale / Cylinder PZ / Cle I

**RBRET1**      **RBRET2**

**WC / Privacy**  
**BAD / Cond/Dec**

**R896OV**

**standard**

finiture standard / standard finishes  
Standardveredelungen / finitions standards

<b>oo</b> - Oro / Polished brass Messing poliert / Laiton poli	•	•	•	•
<b>o6</b> - Cromo lucido / Polish. chrome Chrom / Chrome poli	•	•	•	•
<b>o8</b> - Cromo satinato / Sat. chrome Chrom matt / Chrome satiné	•	•	•	•
<b>33</b> - Nickel sat. vern. / Satin nickel Nickel / Nickel satiné	•	•	•	•
<b>SL</b> - Silver / Silber	•	•	•	•
<b>BA</b> - Bronzo gr. opaco Mat satin bronze Matt satin Bronze Bronze mat satiné	•	•	•	•

Ovale

Ovale

Ovale/WC



## Rosette rettangolari / Rectangular roses Rechteckige Rosetten / Rosaces rectangulaires

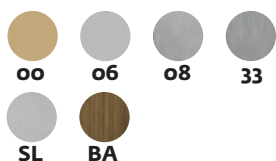

**Rosetta / Rose  
Rosetten / Rosace**

**RRETT**



**Bocchetta / Escutcheon  
Schlüssens rosetten  
Rosace de cle**

Patent / Lock  
BB / Cle L

Yale / Cylinder  
PZ / Cle I

**RBRET1**

**RBRET2**

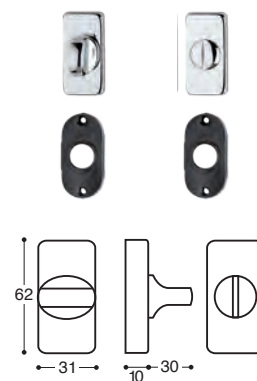

**WC / Privacy  
BAD / Cond/Dec**

**R896RE**



finiture standard / standard finishes  
Standardveredelungen / finitions standards

<b>oo</b> - Oro / Polished brass Messing poliert / Laiton poli	•	•	•	•
<b>o6</b> - Cromo lucido / Polish. chrome Chrom / Chrome poli	•	•	•	•
<b>o8</b> - Cromo satinato / Sat. chrome Chrom matt / Chrome satiné	•	•	•	•
<b>33</b> - Nickel sat. vern. / Satin nickel Nickel / Nickel satiné	•	•	•	•
<b>SL</b> - Silver / Silber	•	•	•	•
<b>BA</b> - Bronzo gr. opaco Mat satin bronze Matt satin Bronze Bronze mat satiné	•	•	•	•

**Rettangolare**

**Rettangolare**

**Rettangolare/WC**



## Serramenti / Window frames / Fenster und Türen / Serrures

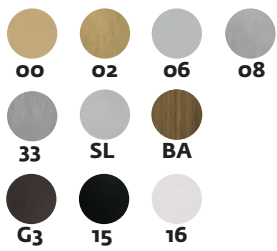

standard



**DK**  
Rosetta / Rosette  
Rosetten / Rosace  
**RDKOVA**



**DKR**  
Rosetta / Rosette  
Rosetten / Rosace  
**RDKRET**

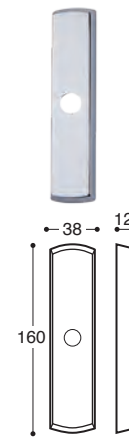

**Cremonese**  
**RCREEL**

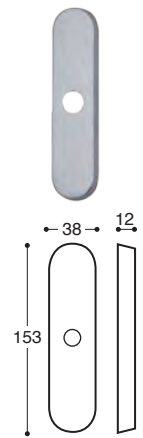

**Cremonese**  
**RCRETI**

finiture standard / standard finishes  
Standardveredelungen / finitions standards

<b>00</b> - Oro / Polished brass Messing poliert / Laiton poli	•	•	•	•
<b>06</b> - Cromo lucido / Polish. chrome Chrom / Chrome poli	•	•	•	•
<b>08</b> - Cromo satinato / Sat. chrome Chrom matt / Chrome satiné	•	•	•	•
<b>33</b> - Nickel sat. vern. / Satin nickel Nickel / Nickel satiné	•	•	•	•
<b>SL</b> - Silver / Silber	•	•	•	•
<b>BA</b> - Bronzo gr. opaco / Mat sat. bronze Matt Sat. Bronze Bronze mat sat.	•	•	•	•

finiture trendy / trendy finishes  
TrendyVeredelungen / finitions trendy

<b>G3</b> - Gun metal	•	•	•	•
<b>15</b> - Nero opaco* / Mat black* Matt schwarz* / Noir mat*	•	•	•	•
<b>16</b> - Bianco* / White* Weiß* / Blanc*	•	•	•	•

**Ovale**

**Rettangolare**

**Elba**

**Tike**

\* a richiesta / on demand / auf Anfrage / sur demande

Meccanismo 8 scatti  
per microventilazione  
Mechanism 8 shots for  
microventilation  
8-facher Mechanismus  
für Mikroventilation  
Mécanisme 8 déclenchements  
pour micro ventilation

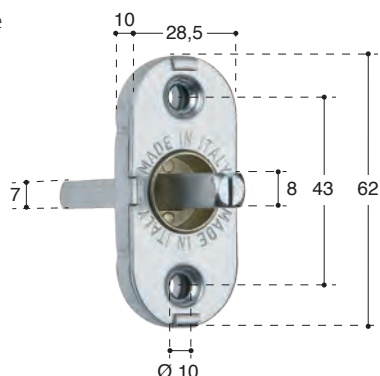

## Serramenti / Window frames / Fenster und Türen / Serrures

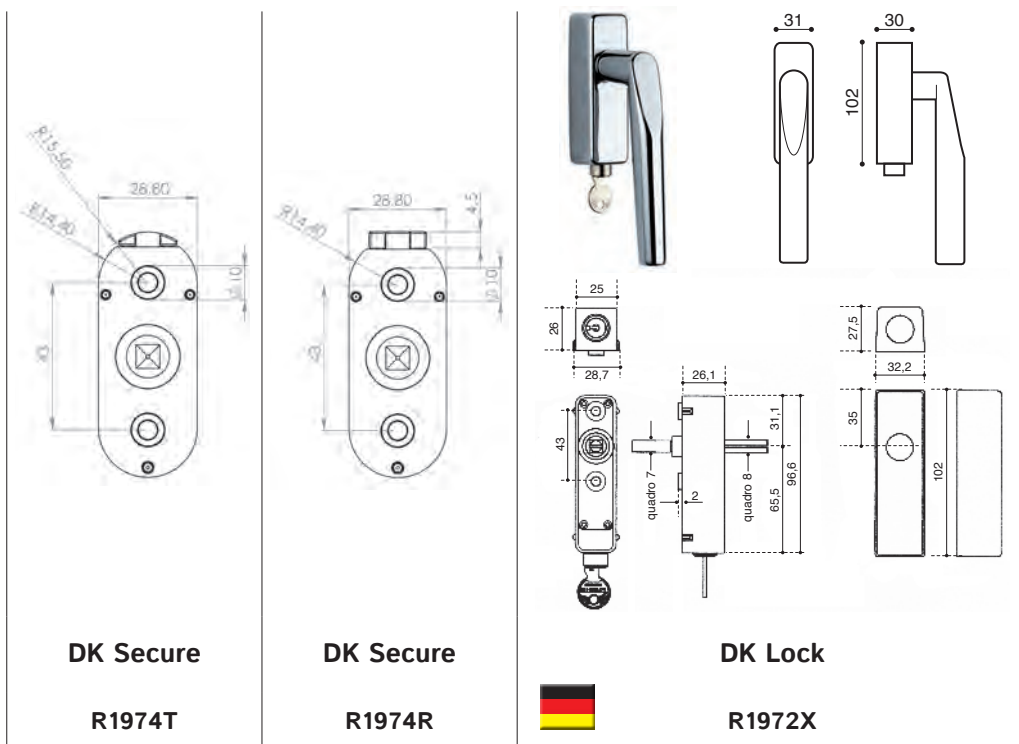
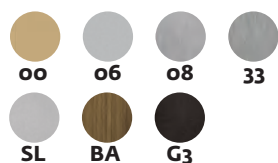

finiture standard / standard finishes  
Standardveredelungen / finitions standards

<b>oo</b> - Oro / Polished brass Messing poliert / Laiton poli	•	•	•
<b>o6</b> - Cromo lucido / Polish. chrome Chrom / Chrome poli	•	•	•
<b>o8</b> - Cromo satinato / Sat. chrome Chrom matt / Chrome satiné	•	•	•
<b>33</b> - Nickel sat. vern. / Satin nickel Nickel / Nickel satiné	•	•	•
<b>SL</b> - Silver / Silber	•	•	•
<b>BA</b> - Bronzo gr. opaco Mat satin bronze Matt satin Bronze Bronze mat satiné	•	•	•

finiture trendy / trendy finishes  
Trendy Veredelungen / finitions trendy

<b>G3</b> - Gun metal	•	•	•
-----------------------	---	---	---

DK secure

DK secure

DK lock



Finiture disponibili / Finishes available / Verfügbare Veredelungen  
Finitions disponibles



**00** - Oro  
Polished brass  
Messing poliert  
Laiton poli



**02** - Ottone satinato  
Satin brass  
Messing matt  
Laiton satiné



**06** - Cromo lucido  
Polished chrome  
Chrom  
Chrome poli



**08** - Cromo satinato  
Satin chrome  
Chrom matt  
Chrome satiné



**22** - Nickel lucido  
Polished nickel  
Nickel poliert  
Nickel poli



**33** - Nickel satinato verniciato  
Satin nickel  
Nickel satiniert lackiert  
Nickel satiné verni



**34** - Nickel satin. vern. opaco  
Satin nickel matt lacquered  
Nickel satiniert lackiert matt  
Nickel satiné verni mat



**SL** - Silver  
Silber



**BA** - Bronzo graffiato opaco  
Mat satin bronze  
Matt satin Bronze  
Bronze mat satiné



**BR** - Bronzo opaco  
Mat bronze  
Matt Bronze  
Bronze mat



**ON** - Ottone naturale  
Natural brass  
Messing nature  
Laiton naturelle



**03** - Oro 24K  
Gold 24K  
Or 24K



**G3** - Gun metal



**15** - Nero opaco  
Mat black  
Matt schwarz  
Noir mat



**16** - Bianco  
White  
Weiß  
Blanc

## Ferri / Spindles / Stift / Mécanismes

standard 			codice / code Kode / code
	Ferro ad espansione Screw fastening spindle Spreizstift Carré avec vis	8 x 65 8 x 45	R1B96500000 R1B9658X045
	Ferro 2 tagli-2 fresate Spindle 2 cuts-2 milled Stift mit 2 Schnitte-2 Fräsungen Carré 2 coupes-2 fraiseuses	8 x 85 8 x 95 8 x 100 8 x 110 8 x 120 8 x 130	R1B9628X085 R1B9628X095 R1B9628X100 R1B9628X110 R1B9628X120 R1B9628X130
	Ferro / Spindle / Stift / Carré	8 x 90 8 x 100 8 x 120 8 x 135 8 x 150	R1B9688X090 R1B9688X100 R1B968000000 R1B9688X135 R1B9688X150
	Ferro 2 tagli-2 fresate Spindle 2 cuts-2 milled Stift mit 2 Schnitte-2 Fräsungen Carré avec 2 coupes + 2 fraisesages	7 x 95 7 x 100	R1B9647X095 R1B9647X100
	Ferro / Spindle / Stift / Carré	7 x 70	R1B96600000
	Ferro con rondella Spindle with washer Stift mit Unterlegscheibe Carré avec rondelle	7 x 80	R1B9667X080
	Ferro con 1 fresatura Spindle with 1 milled Stift mit 1 Schnitte Carré avec fraiseuse	6 x 32 6 x 35 6 x 80	R1B9616X032 R1B9616X035 R1B9616X080
	Ferro / Spindle / Stift / Carré	6 x 100	R1B96700000
	Ferro con 1 taglio e 1 fresata Spindle 1 cut 1 milled Stift mit 1 Schnitte-1 Fräsung Carré 1 coupe-1 fraiseuse	7 x 80	R1B9697X080
	Ferro Dummy / Dummy spindle Dummy Stift / Carré dummy	Q.8	R4T10013
	Dummy filettato Threaded dummy Dummy mit Gewinde Dummy fileté	M8	R4T10039
	Dummy tondo per fissaggio frontale di maniglioni e pomoli Round dummy for pulls and knobs face fixing Runder Dummy für Türgriff- und Knopfflächenbefestigung Dummy rond pour la fixation des poignées et des boutons	Ø 8 mm	R4T10026
	Troncone filettato e dado per fissaggio passante Passing through bolt and nut Gewindestab und Mutter für interne Befestigung Partie fileté et écrou pour fixation passante	10 x 100	R4F110 + codice finitura dado
	Troncone per fissaggio UG Back-to-back bolt Stab für paarweise Befestigung Partie pour fixation UG	10 x 100	R4G03056



## Movimenti / Mechanisms / Mechanismus / Mécanismes

standard 	codice / code Kode / code	
	Tipo A - DK 7 x 42 - 8 scatti	R1B96000000
	Tipo C - Gratz con bussole + Q.7	R1971009
	Tipo D - Gratz con perni	R1971019
	Tipo E - Gratz con bussole	R1971020
	Tipo F - Martellina + Q.7	R1971031
	Tipo G - Gratz con bussole + Q.7	R1971026
	Tipo H - Gratz con perni	R1971027
	Tipo I - Gratz con bussole	R1971025
	DK Secure	R1974XSS
	Serratura per DK con chiave Window DK lock with key DK Fenster mit Schlüssel Serrure pour DK avec clé	R1972XXX

## Strumenti punto vendita / Point of Sale Tools Instrumente Verkaufsstandort / Instruments point de vente



Pannello espositore  
Display board  
Ausstellungstafel  
Panneau exposant

42 x 90 cm



Poster punto vendita  
Selling point poster  
Poster Verkaufsstandort  
Poster point de vente

30 x 60 cm



Valigetta campionario  
Show case  
Musterköfferchen  
Valisette d'échantillons



## Mano maniglie / Hand of handles / Hand der Griffe / Main poignées

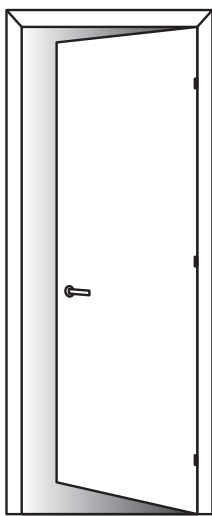

Maniglia DESTRA, cerniere a destra, si impugna con la mano destra per aprire (sia a tirare che a spingere).

RIGHT handle, hinges on the right, you hold with your right hand to open (both pulling and pushing).

RECHTER Griff, Scharnier rechts, wird mit der rechten Hand geöffnet (sowohl ziehen als auch drücken).

Poignée DROITE, charnière à droite, on la saisit de la main droite pour ouvrir (Aussi bien pour tirer que pour pousser).

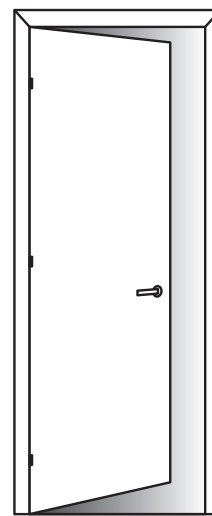

Maniglia SINISTRA, cerniere a sinistra, si impugna con la mano sinistra per aprire (sia a tirare che a spingere).

LEFT handle, hinges on the left, you hold with your left hand to open (both pulling and pushing).

LINKER Griff, Scharnier links, wird mit der linken Hand geöffnet (sowohl ziehen als auch drücken).

Poignée GAUCHE, charnière à gauche, on la saisit de la main gauche pour ouvrir (Aussi bien pour tirer que pour pousser).

## Fissaggio maniglioni / Pulls installation / Tuergriffen Befestigung / Montage des tirants

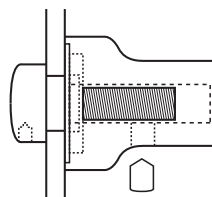

- 1** - Fissaggio con troncone passante  
Fixing with stump through  
Interne Befestigung mit Stab  
Fixation avec partie passante

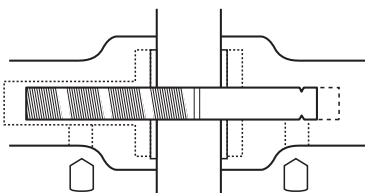

- 2** - Fissaggio UG per paio maniglioni  
UG fixing for two handlebars  
Paarweise Satzbelegung  
Fixation UG pour paires de poignées

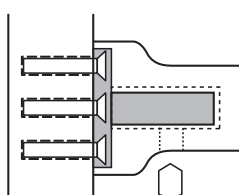

- 3** - Fissaggio frontale con base "dummy"  
Frontal fixation with "dummy" base  
Befestigung vorne mit Basis "dummy"  
Fixation frontale avec base « dummy »

#### Eros Damiano Mauroner - biografia - [www.mauroner.it](http://www.mauroner.it)

Fotografo professionista dal 1985, specializzato nella fotografia di still-life, di architettura, di reportage e nella tecnica del light-painting. Attraverso uno studio approfondito sulla figura, crea immagini fortemente caratterizzate da scelte allegoriche. È presente in numerose esposizioni personali e collettive in varie sedi nazionali ed estere. Si dedica inoltre alla realizzazione di video-reportage sulla storia e le identità locali ed internazionali, con una particolare attenzione e passione per l'aspetto antropologico. È docente di fotografia presso l'Istituto Golgi e l'Accademia LABA. Vive a Brescia. RCS pubblica il libro "Corriere", un libro di fotografia d'architettura, sulle sedi di Milano e Roma del Corriere della Sera con fotografie di Gabriele Basilico e con fotografie di Eros Mauroner. Le tematiche sociali e storiche fanno parte dei suoi principali interessi fin da studente, a queste dedica una cospicua parte della sua ricerca.

Professional photographer since 1985, specializing in photography of still-life, architecture, reportage and light-painting technique. Through an in-depth study of the figure, he creates images strongly characterized by allegorical choices. He is present in numerous personal and collective exhibitions at various domestic and foreign venues. He is also dedicated to the production of video-reportages on history and local and international identities, with particular attention and passion for the anthropological aspect. He is a professor of photography at the Golgi Institute and the LABA Academy. He lives in Brescia. RCS publishes the book "Corriere", a book of architecture photography, on the offices of Milan and Rome of Corriere della Sera with photographs by Gabriele Basilico and photographs by Eros Mauroner. Social and historical themes are part of his main interests as a student, devoting a substantial part of her research.

Professioneller Fotograf seit 1985, spezialisiert auf das Fotografieren von Stilleben, Architektur, Reportage und in der Light-Painting-Technologie. Nach einer intensiven Beobachtung der Figur erzeugt er Bilder, die von allegorischen Entscheidungen stark beeinflusst sind. Er ist Teil vieler persönlicher oder gesammelter Ausstellungen im In- und Ausland. Er widmet sich außerdem der Erstellung von Video-Reportagen über die Geschichte lokaler und internationaler Völker und berücksichtigt dabei besonders den anthropologischen Aspekt. Er ist Dozent für Fotografie am Golgi Institut und der Accademia LABA. Er lebt in Brescia. RCS veröffentlicht das Buch „Corriere“, ein Architektur-Fotobuch über die Firmensitze der Zeitung Corriere della Sera in Mailand und Rom, von Gabriele Basilico mit Fotos von Eros Mauroner. Soziale und geschichtliche Themen sind schon seit Studienzeiten seine größten Interessen und ihnen widmet er auch den größten Teil seiner Forschungsarbeit.

Photographe professionnel depuis 1985, spécialisé dans la photographie de still-life, d'architecture, de reportage et dans la technique du light-painting. À travers une étude approfondie de la forme, il crée des images fortement caractérisées par des choix allégoriques. Il est présent dans de nombreuses expositions personnelles et collectives dans différentes résidences nationales et étrangères. Il se consacre en outre à la réalisation de reportages vidéo sur l'histoire et les identités locales et internationales, avec une attention et une passion particulières pour l'aspect anthropologique. Il est professeur de photographie à l'Institut Golgi et à l'Académie LABA. Il vit à Brescia. RCS publie le livre « Corriere », un livre de photographies d'architecture, sur les sièges de Milan et de Rome du Corriere della Sera avec des photographies de Gabriele Basilico et avec des photographies d'Eros Mauroner. Les thèmes sociaux et historiques font partie de ses principaux intérêts depuis qu'il est étudiant, et il consacre à cela une partie considérable de ses recherches.

# KLEIS

**GIARA S.r.l.**

Via San Lino, 47 - 25071 AGNOSINE (BS) - Italy

Tel. +39.0365.860539 / 823030

Fax +39.0365.869366 / 839908

e-mail [info@giara.info](mailto:info@giara.info)

[www.kleisdesign.it](http://www.kleisdesign.it)